

DWR625-205

DWR

Pressure limiters

Especially suitable as a pressure limiter for fuel gases (DVGW work sheet G 260) and liquid fuels (e.g. fuel oil), as well as for steam systems according to TRBS and hot water systems to DIN EN12828, systems in accordance to DIN EN12952-11 and DIN EN12953-9.

The DWR-205/-206 is used to limit maximum and minimum pressures and has an internal interlock.



SIL 2 according IEC 61508-2

Technical data

Pressure connection

External thread G 1/2 (pressure gauge connection) to DIN 16 288 and internal thread G 1/4 to ISO 228 Part 1 (for gas applications internal thread permissible only up to 4 bar).

Switching device

Rugged housing (200) made of seawater resistant die cast aluminium.

Materials

Pressure bellows: Material no. 1.4571
 Sensor housing: Material no. 1.4104
 Switch housing: GD Al Si 12 (DIN 1725)

Mounting position Vertically upright and horizontal.

Ambient temperature at switching device
 -25...+70°C

Medium temperature -25...+70°C.

The medium temperature at the pressure sensor must not exceed the permitted ambient temperature at the switching device. Temperatures may reach 85°C for short periods. Higher medium temperatures are possible provided the above limit values for the switching device are ensured by suitable measures (e.g. siphon).

Mounting

Directly on the pressure line (pressure gauge connection) or on a flat surface with two 4 mm Ø screws.

Calibration

The DWR-205 series is calibrated for rising pressure. This means that the adjustable switching pressure on the scale corresponds to the switching point at rising pressure. The reset point is lower by the amount of the switching differential. (See also page 23, 2. Calibration at upper switching point). The DWR-206 series is calibrated for falling pressure. This means that the adjustable switching pressure on the scale corresponds to the switching point at falling pressure. The reset point is higher by the amount of the switching differential. (See also page 23, 1. Calibration at lower switching point).

Bursting pressure For all types ≥ 100 bar, verified by TÜV test.

Switching differential For values see Product Summary.

Contact arrangement Single pole change over switch.

Switching capacity	250 VAC		250 VDC	24 VDC
	(ohm)	(ind)	(ohm)	(ohm)
Normal	8 A	5 A	0.3 A	8 A

Protection class IP 54 according to DIN 40 050

Sealing P2

On request (can be fitted later).

Component tested for

Steam

System according to TRBS

Hot water

System according to DIN EN12828

Fuel gases

DVGW work sheet G 260

Pressure tank

DIN EN764-7

Function

Pressure limiter (with internal interlock)

Direction of action

For maximum and minimum pressure monitoring (SDBFS)

Sensor

"Of special construction" by testing with 2 million cycles.

Important: When selecting the limiter, it is necessary to decide whether the device is to be used for maximum or minimum pressure monitoring. The direction of action cannot be reversed at the pressure limiter.

Product Summary

Type	Setting range	Switching differential (Tolerance)	Maximum working pressure	Dimensioned drawing
Maximum pressure limiters				page 21 + 22
DWR06-205	0,1...0,6 bar	35 ... 73 mbar	6 bar	1 + 15
DWR1-205	0,2...1,6 bar	53 ... 111 mbar		
DWR3-205	0,2...2,5 bar	107 ... 218 mbar	16 bar	1 + 18
DWR6-205	0,5...6 bar	0,17 ... 0,35 bar		
DWR625-205	0,5...6 bar	0,22 ... 0,45 bar	25 bar	1 + 17
DWR16-205	3...16 bar	0,40 ... 0,81 bar		
DWR25-205	4...25 bar	0,80 ... 1,67 bar	63 bar	1 + 16
DWR40-205	8...40 bar	1,32 ... 2,75 bar		
Minimum pressure limiters				
DWR06-206	0,1...0,6 bar	35 ... 73 mbar	6 bar	1 + 15
DWR1-206	0,2...1,6 bar	53 ... 111 mbar		
DWR3-206	0,2...2,5 bar	107 ... 218 mbar	16 bar	1 + 18
DWR6-206	0,5...6 bar	0,17 ... 0,35 bar		
DWR625-206	0,5...6 bar	0,22 ... 0,45 bar	25 bar	1 + 17
DWR16-206	3...16 bar	0,40 ... 0,81 bar		
DWR25-206	4...25 bar	0,80 ... 1,67 bar	63 bar	1 + 16
DWR40-206	8...40 bar	1,32 ... 2,75 bar		

Pressure monitors DWR... (page 55) can also be used as maximum pressure and minimum pressure limiters with external interlock. You will find other maximum pressure limiters with safety sensor, type series SDBAM..., on page 49. Types DWAM... can also be used with external interlock as maximum pressure limiters.

Mechanical pressure switches

Technical features / Advantages

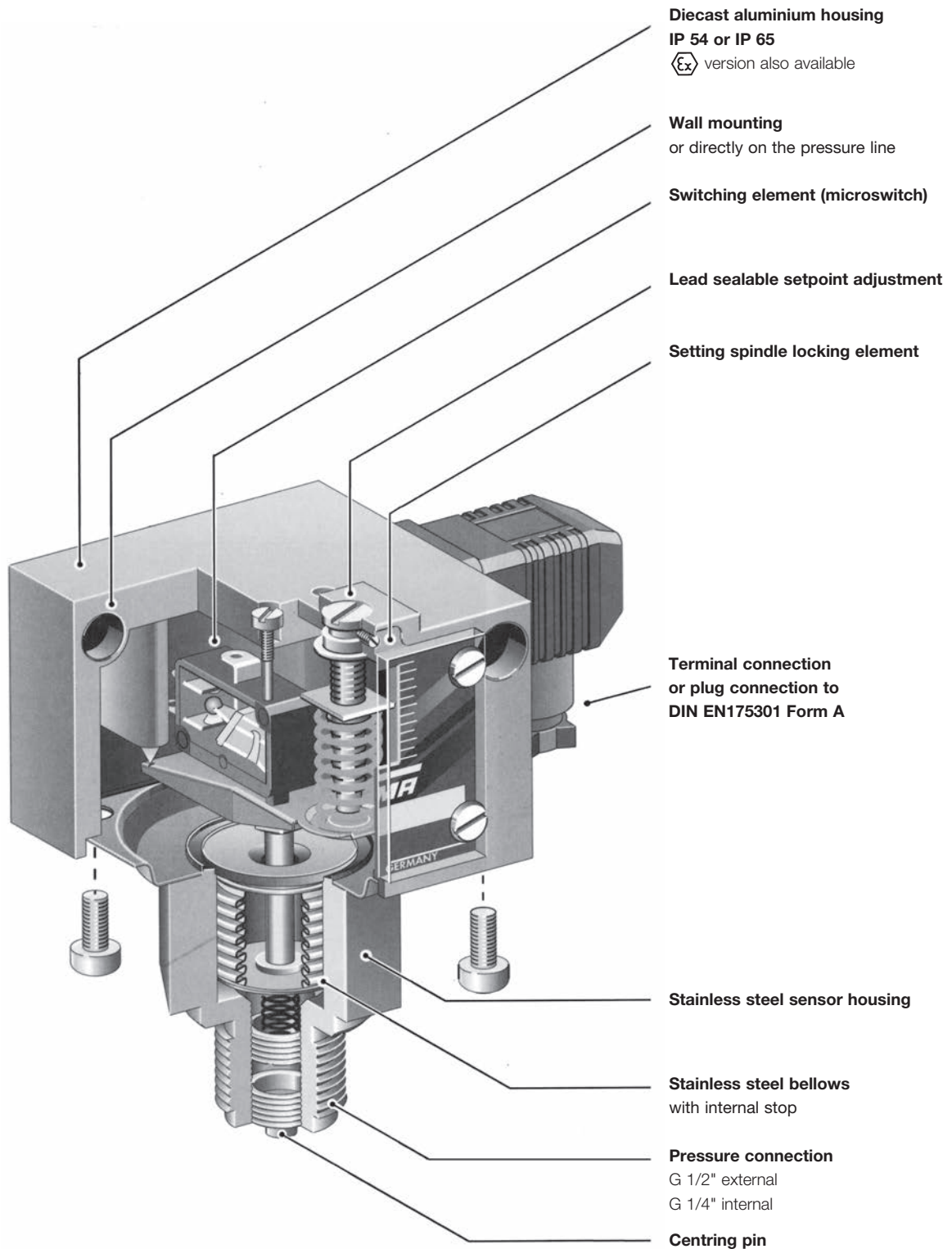

Definitions

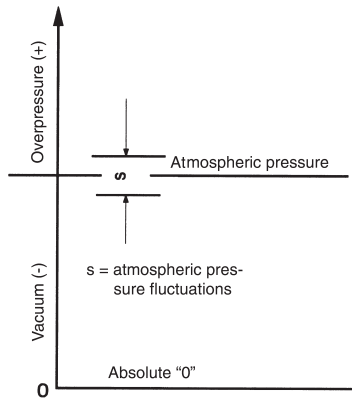

Pressure data

- Overpressure** Pressure **over** the relevant atmospheric pressure. The reference point is atmospheric pressure.
- Vacuum** Pressure **under** the relevant atmospheric pressure. The reference point is atmospheric pressure.
- Absolute pressure** Overpressure relative to absolute vacuum.
- Differential pressure** Difference in pressure between 2 pressure measuring points.
- Relative pressure** Overpressure or vacuum relative to atmospheric pressure.

Pressure data in all FEMA documents refers to relative pressure.

That is to say, it concerns pressure differentials relative to atmospheric pressure. Overpressures have a positive sign, vacuums a negative sign.

Permissible working pressure (maximum permissible pressure)

The maximum working pressure is defined as the upper limit at which the operation, switching reliability and water tightness are in no way impaired (for values see Product summary).

Bursting pressure (test pressure)

Type-tested products undergo a pressure test certified by TÜV affirming that the bursting pressure reaches at least the values mentioned in the Product summary. During the pressure tests the measuring bellows are permanently deformed, but the pressurized parts do not leak or burst. The bursting pressure is usually a multiple of the permissible working pressure.

Setting range

Pressure range in which the cutoff pressure can be set with the setting spindle.

Pressure units

Unit	bar	mbar	Pa	kPa	MPa	(psi) lb/m ²
1 bar	1	1000	10 ⁵	100	0.1	14.5
1 mbar	0.001	1	100	0.1	10 ⁻⁴	0.0145
1 Pa	10 ⁻⁵	0.01	1	0.001	10 ⁻⁶	1.45 · 10 ⁻⁴
1 kPa	0,01	10	1000	1	0.001	0,145
1 MPa	10	10 ⁴	10 ⁶	1000	1	145

In FEMA documents pressures are stated in **bar** or **mbar**.

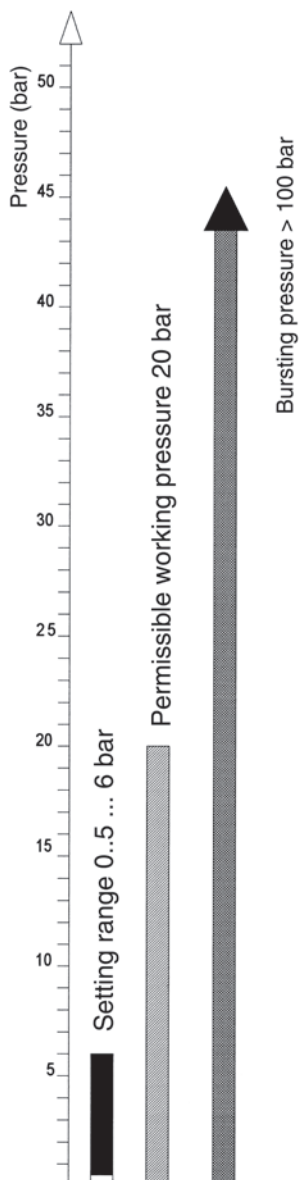

Pressure data for a pressure switch based on the example of DWR625:

Setting range: 0.5-6 bar
 Perm. working pressure: 20 bar
 Bursting pressure: >100 bar

Important:

All pressure data refers to overpressures or vacuums relative to atmospheric pressure. Overpressures have a positive sign, vacuums a negative sign.

Definitions

Maximum pressure monitoring

$$RSP = SP - xd$$

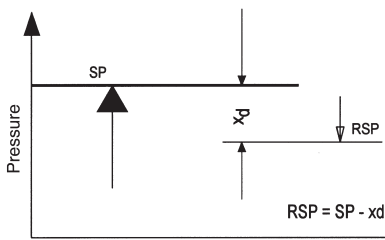

SP = switching point RSP = reset point
xd = switching differential (hysteresis)

Minimum pressure monitoring

$$RSP = SP + xd$$

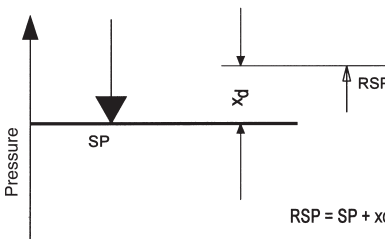

SP = switching point RSP = reset point
xd = switching differential (hysteresis)

Switching differential

The switching differential (hysteresis) is the difference in pressure between the **switching point (SP)** and the **reset point (RSP)** of a pressure switch. Switching differential tolerances occur due to tolerances in the microswitches, springs and pressure bellows. Therefore the data in the product summaries always refers to average values. In the case of limiter functions the switching differential has no significance, as one is only interested in the switching point at which cutoff occurs, not the reset point. For a **controller function**, i. e. in the case of pressure switches used to switch a burner, pump etc. **on and off**, a pressure switch with an **adjustable switching differential** should be chosen. The switching frequency of the burner or pump can be varied by changing the switching differential.

Adjustable switching differential/ calibration

In the case of pressure switches with adjustable switching differential, the hysteresis can be set within the specified limits. The switching point (SP) and reset point (RSP) are precisely definable. When setting the pressure switch, the switching differential situation and the type of factory calibration must be taken into account. Some pressure switches (e.g. minimum pressure monitors of the DCM series) are calibrated under "falling" pressure, i.e. switching under falling pressure takes place at the scale value with the switching differential being above it. The device switches back at scale value + switching differential. If the pressure switch is calibrated under rising pressure, switching takes place at the scale value and the device switches back at scale value - switching differential (see direction of action). The calibration method is indicated in the data sheets.

Direction of action

In principle, any pressure switch can be used for both maximum pressure and minimum pressure monitoring. This excludes pressure limiters, whose direction of action (maximum or minimum) is predefined. The only thing to remember is that the scale reading may deviate by the amount of the switching differential. See example at bottom left: The scale value is 2.8 bar.

Maximum pressure monitoring

With rising pressure, switching takes place once the preset switching pressure is reached (SP). The reset point (RSP) is lower by the amount of the switching differential.

Minimum pressure monitoring

With falling pressure, switching takes place once the preset switching pressure is reached (SP). The reset point (RSP) is higher by the amount of the switching differential.

Direction of action in vacuum range

It is particularly important to define the direction of action in the vacuum range.

Rising does not mean a rising vacuum, but rising pressure (as viewed from absolute "0"). "Falling" pressure means a rising vacuum.

For example: Vacuum switch set to -0.6 bar falling means: Switching (SP) takes place under falling pressure (rising vacuum) at -0.6 bar. The reset point is higher by the amount of the switching differential (e.g. at -0.55 bar).

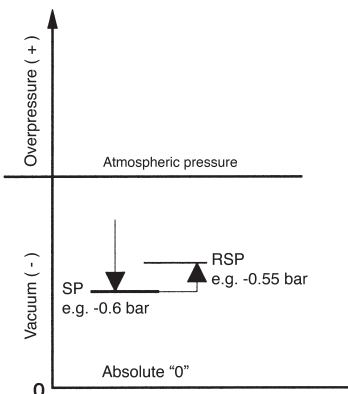

Setting a pressure switch

To define the switching point of a pressure switch exactly, it is necessary to determine the direction of action in addition to the pressure. "Rising" means that switching takes place at the set value when the pressure rises.

The reset point is then lower by the amount of the switching differential. "Falling" means exactly the opposite.

Please note when specifying the setting of a pressure switch:

In addition to the switching point it is also necessary to specify the direction of action (falling or rising).

Example for selection of a pressure switch:

A pump is to be turned on at 2.8 bar and off again at 4.2 bar.

Chosen type: DCMV6 according to data sheet DCM. Setting: Scale pointer to 2.8 bar (lower switching point). Switching differential to 1.4 bar (set according to pressure gauge). Cutoff point: 2.8 bar + 1.4 bar = 4.2 bar.

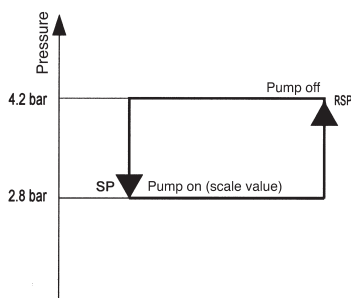

SP = switching point RSP = reset point

Operating mode

The pressure prevailing in the sensor housing (1) acts on the measuring bellows (2). Changes in pressure lead to movements of the measuring bellows (2) which are transmitted via a thrust pin (4) to the connecting bridge (5). The connecting bridge is frictionlessly mounted on hardened points (6). When the pressure rises the connecting bridge (5) moves upwards and operates the microswitch (7). A counter-force is provided by the spring (8), whose pre-tension can be modified by the adjusting screw (9) (switching point adjustment). Turning the setting spindle (9) moves the running nut (10) and modifies the pre-tension of the spring (8). The screw (11) is used to calibrate the microswitch in the factory. The counter pressure spring (12) ensures stable switching behaviour, even at low setting values.

- 1 = Pressure connection
- 2 = Measuring bellows
- 3 = Sensor housing
- 4 = Thrust pin
- 5 = Connecting bridge
- 6 = Pivot points
- 7 = Microswitch or other switching elements
- 8 = Setting spring
- 9 = Setting spindle (switching point adjustment)
- 10 = Running nut (switching point indicator)
- 11 = Microswitch calibration screw (factory calibration)
- 12 = Counter pressure spring

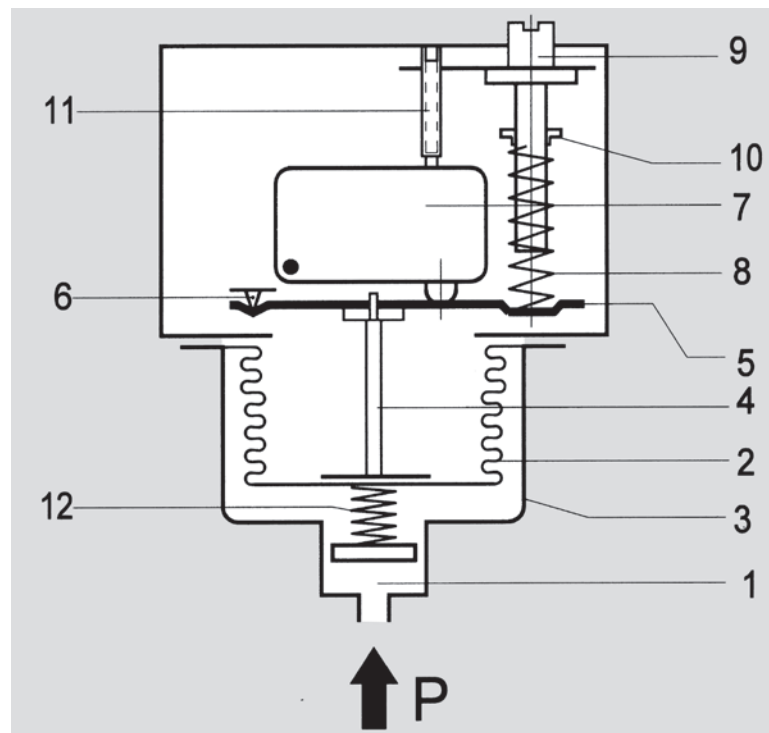

Pressure sensors

Apart from a few exceptions in the low-pressure range, all pressure sensors have measuring bellows, some made of copper alloy, but the majority of high-quality stainless steel. Measured on the basis of permitted values, the measuring bellows are exposed to a minimal load and perform only a small lifting movement. This results in a long service life with little switching point drift and high operating reliability. Furthermore, the stroke of the bellows is limited by an internal stop so that the forces resulting from the overpressure cannot be transmitted to the switching device. The parts of the sensor in contact with the medium are welded together without filler metals. The sensors contain no seals. Copper bellows, which are used only for low pressure ranges, are soldered to the sensor housing. The sensor housing and all parts of the sensor in contact with the medium can also be made entirely from stainless steel 1.4571 (DNS series). Precise material data can be found in the individual data sheets.

Pressure connection

The pressure connection on all pressure switches is executed in accordance with DIN 16288 (pressure gauge connection G 1/2A). If desired, the connection can also be made with a G 1/4 internal thread in accordance with ISO 228 Part 1.

Maximum screw-in depth on the G 1/4 internal thread = 9 mm.

Centring pin

In the case of connection to the G 1/2 external thread with seal in the thread (i.e. without the usual stationary seal on the pressure gauge connection), the accompanying centring pin is not needed. Differential pressure switches have 2 pressure connections (max. and min.), each of which are to be connected to a G 1/4 internal thread.