



Catalog - August 2016

Arc Guard System™ – TVOC-2

Ordering details



Arc Monitor with HMI

1SFC170004F0002



Arc Monitor with COM Module

1SFC170001V0001



Extension unit

1SFC170012R0001



HMI

1SFC170013R0001



COM Module

1SFC170002V0001



Detector cable

1SFC170011F0001

Ordering details

Description	Rated supply voltage Uc		Type	Order code	Weight (1 pce)
	V 50/60 Hz	V DC			
Arc Monitor including one HMI and door mounting accessories	-	24...48	TVOC-2-48	1SFA664001R1002	0.95
	100...240	100...250	TVOC-2-240	1SFA664001R1001	
Arc Monitor including one COM Module and door mounting accessories	-	24...48	TVOC-2-48-C	1SFA664001R1004	0.95
	100...240	100...250	TVOC-2-240-C	1SFA664001R1003	

Accessories

Extension 10 optical inputs	TVOC-2-E1	1SFA664002R1001	0.15
Extension 10 optical inputs for cable TVOC-2-DP60 only	TVOC-2-E3	1SFA664002R3001	0.15
HMI (Human machine interface) additional	TVOC-2-H1	1SFA664002R1005	0.15
COM Module with communication interface (Modbus RTU) and door mounting accessories	TVOC-2-COM	1SFA664002R4001	0.15

Detectors

Cable length	1 m	TVOC-2-DP1	1SFA664003R1010	0.02
Cable length	2 m	TVOC-2-DP2	1SFA664003R1020	0.02
Cable length	4 m	TVOC-2-DP4	1SFA664003R1040	0.04
Cable length	6 m	TVOC-2-DP6	1SFA664003R1060	0.60
Cable length	8 m	TVOC-2-DP8	1SFA664003R1080	0.80
Cable length	10 m	TVOC-2-DP10	1SFA664003R1100	0.10
Cable length	15 m	TVOC-2-DP15	1SFA664003R1150	0.15
Cable length	20 m	TVOC-2-DP20	1SFA664003R1200	0.20
Cable length	25 m	TVOC-2-DP25	1SFA664003R1250	0.25
Cable length	30 m	TVOC-2-DP30	1SFA664003R1300	0.30
Cable length (1)	60 m	TVOC-2-DP60	1SFA664003R3600	0.60

(1) Only to be used with TVOC-2-E3

Technical data

Settings and indications		
Connections for HMI on base module		1 output RJ45 male at front side 1 output RJ14 female at right side
Display on HMI		52 x 26 mm graphic LCD with LED backlight
Keyboard on HMI		Membrane buttons, 4 soft keys
LED signal on HMI		Power, Trip, Error
LED signal on Arc Monitor and extension units		Power, Trip
Configuration switches		8-pole DIP-switch on Arc Monitor front
Settings (HMI)		Time and display language
COM Module version		Modbus RTU protocol
Configuration (DIP switches)		Manual or auto reset of K2 and K3 Use of CSU or not Trip configuration
Display information		Trip log, connected modules, actual configuration self diagnostic test result and error log
Power supply	TVOC-2-240	TVOC-2-48
Rated supply voltage, U_s	100-240 V AC, 50-60 Hz 100-250 V DC	24 - 48 V DC Possibility to connect two power supplies for redundancy. (Common minus)
U_s variation	AC -20% – +10% DC -25% – +30%	DC -25% - +30%
Rated insulation voltage, U_i	250 V with reinforced insulation	250 V with reinforced insulation
Rated impulse withstand Voltage U_{imp}	4 kV	4 kV
Main MCB/fuse	Max. 10 A char. C/fuse 10 A gG	Max 6A, MCB ABB Type S202 Z6A
Power consumption	5 W	5W
Start-up time	< 15 ms from power on	< 100 ms from power on
Trip possible		
Reaction time		
From light detection to trip (contacts K4, K5, K6)		Approx. 1 ms (depends on light intensity)
From light detection to indication signal (relay K2, K3)		< 10 ms
Current condition from input to output		< 0.4 ms
Environmental conditions		
Altitude		Less than 2000 m above sea level.
Permissible ambient temperature		-25 to +55°C
Degree of protection		IP20 Arc Monitor IP54 HMI front side
Detector cable		
Maximum length		30 m with Arc Monitor and extension – E1 60 m with extension – E3
Service temperature range		-25 to +70°C continuous -25 to +85°C short-time
Smallest permissible bending radius		45 mm after installation 10 mm on handling
Acceptable backlight intensity light without tripping		3000 Lux
Optical cable		
Maximum length		30 m
Standards		
		
UL508		Industrial control equipment
CSA C22.2 No.14		Industrial control equipment
IEC 61508		Functional safety of electrical/electronic/programmable electronic safety-related systems
IEC EN60947-1		Low voltage switchgear and controlgear – Part 1: General rules
IEC EN60947-5-1		Low voltage switchgear and controlgear – Part 5-1: Control circuit devices and switching elements - Electromechanical control
IEC 61010-1		Safety requirements for electrical equipment for measurement, control and laboratory use

Circuit diagrams

Arc Monitor

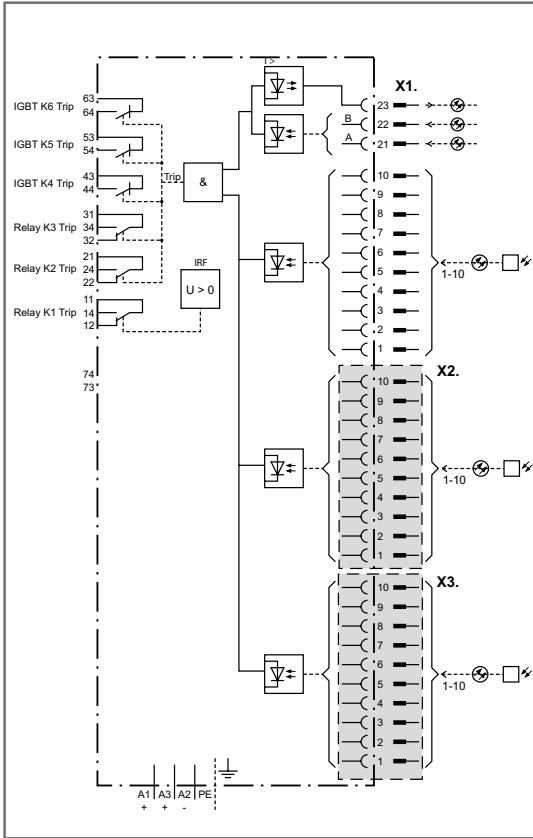

TVOC-2-48 1SFA6641001R1002

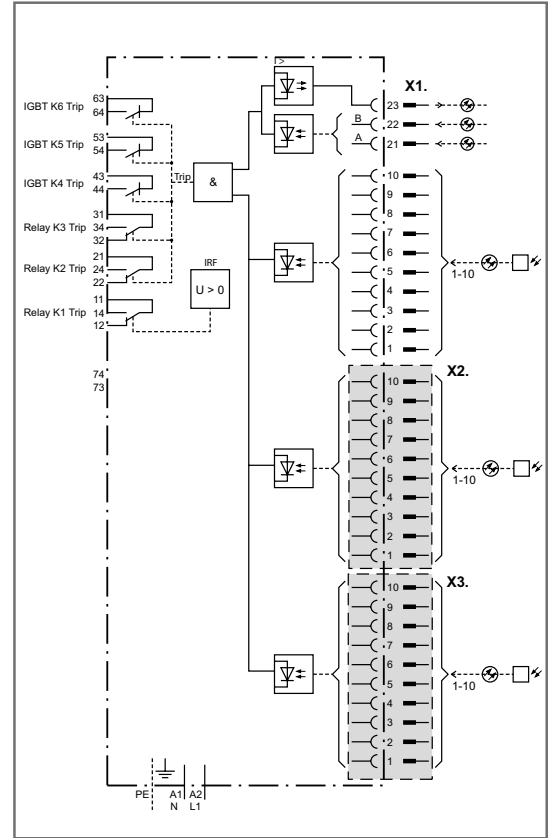

TVOC-2-240 1SFA664001R1001

Arc Monitor Terminals

X1 1-10	Detector input
X2 1-10	Extra detector unit detector input (option)
X3 1-10	Extra detector unit detector input (option)
A1, A2	Power supply
TVOC-2-48: A1, A2, A3	Power supply
PE	Power supply
43, 44	Solid-state contacts
53, 54	Solid-state contacts
63, 64	Solid-state contacts
11, 12, 14	Indication contacts
21, 22, 24	Indication contacts
31, 32, 34	Indication contacts

Current Sensing Unit

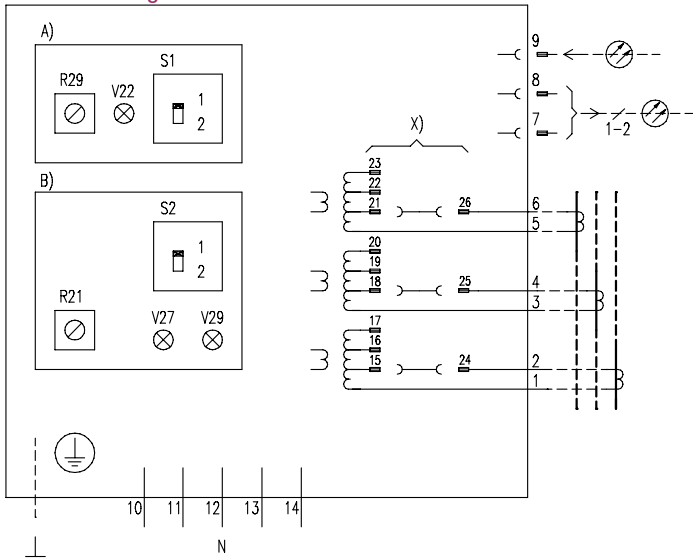

Current Sensing Unit Terminals

1 ... 6	Current transformer terminals
7 and 8	Output current signal to another Current Sensing Unit or Arc Monitor
9	Input current signal from another Current Sensing Unit

Power supply terminals

10 and 12	24 V DC
11 and 12	60 V DC
11 and 12	48 V DC Interconnection 11-13
13 and 12	110 V - 125 V AC / DC
14 and 12	220 V DC, 230 V AC

A) Testing facilities:

R29	Simulating a test current
S1	1 = Test position 2 = Operation position
V22	Red ON = S1 in test position OFF = S1 in operation position

B) Setting facilities:

R21	Overcurrent setting
S2	1 = Input 9 not used 2 = Input 9 used
V27	Yellow ON = Load current less than 70% of set overcurrent level OFF = Load current more than 70% of overcurrent level
V29	Green ON = Load current less than set overcurrent level OFF = Load current more than set overcurrent level

X) Current range bridge connections

1A:	24-17, 25-20, 26-23
2A:	24-16, 25-19, 26-22
5A:	24-15, 25-18, 26-21