

5.2 Input/output module EB11

Order No. 6DD1641-0AC0

Features

- 32 binary inputs and outputs
- 2 40-pin connectors
- 2*8 binary inputs and outputs per connector
- binary outputs with thermal overload protection
- 2 LED keys to reset after an overload condition
- L-bus connection

Overload protection

An overloaded binary output due to an excessively high current (thermal overload, e. g. short-circuit) is electronically shutdown. The output is switched into an open-circuit condition. The LED key of the associated connector lights-up.

The associated output is operational again after a recovery time (during which time it cools-down). To realize this, the associated electronics must be **reset**; this can be done in 2 ways:

- Using the **background program** of the CPU module, on which the associated binary output function block is configured.
For a normal CPU utilization, this reset takes several seconds after cooling-down.
Resetting can take somewhat longer for extremely high CPU loading levels.
- By depressing the illuminated **LED key**.
Key assignment:
 - connector X5: Key S1
 - connector X6: Key S2

5.2.4 Technical data

General data

No. of slots occupied	1
Dimensions W x H x D [mm]	20.14 x 233.4 x 220
Weight	Approx. 0.6 kg

Power supply

Rated voltage	min.	max.	Typ. current drain
+5 V	+4.75 V	+5.25 V	420 mA
-15 V	-15.6 V	-14.4 V	20 mA (only as reference)
+24V	+20 V	+30 V	0,2 A (from an external power supply) + current drain of the connected SB70, SB71 interface modules + current drain from the binary outputs which are directly connected at the binary outputs of the connected components (when using SB10, SU11, SU12)

Binary inputs

No.	2 x 16
Input voltage	+24 V rated value
for 0 signal	-1 V to +6 V; or open-circuit binary inputs
for 1 signal	+13 V to +33 V
Input current for an 1 signal	5 mA typ.
Delay time	200 µs

Binary outputs

No.	2 x 16
Power supply voltage	
rated value	+24 V DC
ripple	3.6 V DC
permissible range	+20 to +30 V, including ripple
briefly	+35 V for < 0.5 s
Output current for a 1 signal	
rated value	50 mA
permissible range	0.2 mA to 50 mA
Short-circuit protection	Thermal / electronic
Limiting inductive switch-off voltage	To the supply +1 V
Residual current	20 µA for a 0 signal
Signal level	
for 0 signal	Max. 3 V
for 1 signal	Min. supply - 2.5 V
Delay time	15 µs

5.2.5 Connecting diagram

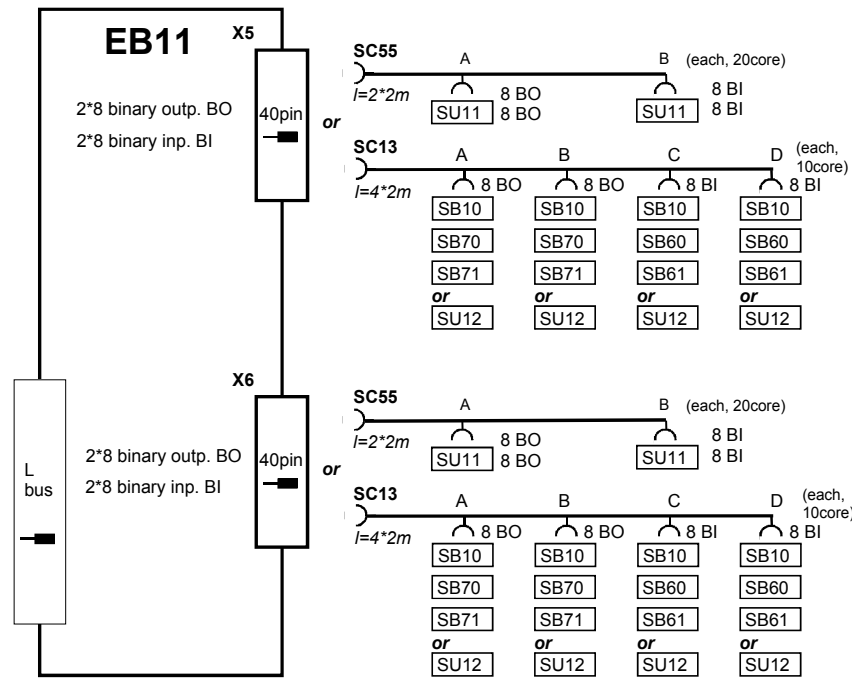

Fig. 5-2 Connecting cables and interface modules