

## 5.5 Converter control ITDC

**Order No.** 6DD1601-0AH0  
**Description** The ITDC expansion module corresponds to the earlier PG16 module, and provides the gating (control) for

- line-commutated drive converters.

It includes:

- Auto-reversing stage
- Current controller
- Gating unit (for max. 400 Hz output frequency)
- For 6-pulse drive converters

It is especially suitable for connection to SITOR power sections.

The expansion module is inserted on a CPU module (PM5, PM6). A maximum of 2 expansion modules ITxx can be inserted on a CPU module. One ITxx occupies 1 slot (in addition to the slot in the CPU module). Presently, the operation of 2 ITDC modules in one processor module is not supported.

### Inputs and outputs

- 1 SITOR interface
- 2 analog outputs
- 4 binary outputs
- 4 binary inputs
- 1 incremental encoder input:
  - With zero pulse
  - Optionally, for differential signals
  - For tracks, shifted through 90 degrees (A, B)
  - For 15 V (HTL)- or 5 V encoders
  - Max. 1 MHz pulse frequency
- No electrical isolation of the inputs-/outputs

### Incremental encoder setting

Incremental encoders can be connected to the ITDC, with the following signal voltages

- 15V
- 5V (also as push - pull signals and RS485 differential signals)

The incremental encoder type is selected using DIL switch S1 on the component side of the ITDC (refer to the following diagram ).

There is the following assignment of the DIL switch settings S1.X to the pulse encoder channels :

Switch	Switch setting	Function
S1.1	ON	Track A, zero volt switching threshold f. 5V encoders
S1.1	OFF	Track A, 7V switching threshold f. 15V encoders
S1.2	ON	Track B, zero volt switching threshold f. 5V encoders
S1.2	OFF	Track B, 7V switching threshold f. 15V encoders
S1.3	ON	Zero pulse, 0V switching threshold f. 5V encoders
S1.3	OFF	Zero pulse, 7V switching threshold f. 15V encoders
S1.4	any	none

### 5.5.5 Technical data

#### General data

Insulation group	A according to VDE 0110 § 13 Group 2 for 24 V DC, 15 V DC, 5 V DC
Ambient temperature	0 to +55 degrees C and fan operation (force ventil.)
Storage temperature	-25 to +70 degrees C
Humidity rating	F according to DIN 40050
Altitude rating	S according to DIN 40040
Mechanical rating	Installed in stationary equipment, which is not necessarily vibration-free
Packaging system	ES 902 C
Dimensions	233.4 mm * 220 mm
Module width	20.14 mm
Installation size	1 slot
Weight	600 g

#### Power supply

Rated voltage	min.	max.	Typ. current drain
+5 V	+4.75 V	+5.25 V	100 mA
+15 V	+14.4 V	+15.6 V	490 mA (+ encoder load)
-15 V	-15.6 V	-14.4 V	75 mA
24 V (external)	+15V	+30 V	70 mA (+ load of the binary outputs)

#### Analog outputs, connector X5

No.	2
Version	Output with associated ground, non-floating
Output voltage range	-10 V to +10 V
Output current	+/- 10 mA
Resolution	12 bits
Monotony	10 bits over the complete temperature range
Absolute accuracy	Typ. 9 bits over the complete temperature range
Short-circuit protection to ground	Yes

#### Binary inputs connector X6

No.	4 non-floating	
Input voltage	24 V DC rated voltage	
	For 0 signal	-1 V to +6 V or inputs open-circuit
	For 1 signal	+13 V to +33 V
Input current		
	For 0 signal	0 mA
	For 1 signal	3 mA typ.
Delay time	120 µs	

**Binary outputs connector X6**

No.	4, non-floating
Supply voltage	Must be supplied externally
Nominal value	24 V DC
Permiss. range	+20 V to 30 V, including ripple
Briefly	+35 V, max. 0.5 s
Output current for 1 signal	
Rated current	50 mA
Permiss. range	To 50 mA
Short-circuit protection	Electronic (thermal)
Limiting inductive switch-off voltages	+ 1 V power supply voltage
Total load	80 % at 50 degrees C, all outputs 50 mA
Residual current	20 µA for a 0 signal
Signal level	
For 0 signal	Max. 3 V
For 1 signal	- 2.5 V power supply voltage
Switching delay	1->0: max. 10 µs 0->1: max. 100 µs

**Incremental encoders**

No. of encoders	1, non-floating
Version	Differential inputs without electrical isolation, can be changed over between 5V/15V(HTL)
Track signals	Tracks A and B (phase shifted through 90 degrees), if required with zero pulse N
Pulse frequency	Max. 1 MHz (track frequency)
Phase difference of the track signals	Independent of the pulse frequency, min 200 ns
Input voltage for 15V (HTL)	
For 0 signal	-30 V to +5 V
For 1 signal	+8 V to + 30 V
Input voltage for 5V	
For 0 signal	-7 V to -1.5 V
For 1 signal	+1.5 V to + 7 V
Permissible input voltage range	Differential voltage, -30 V to +30 V
Input resistance	Approx. 40K
Fault pulse suppression	Can be configured at the speed actual value function block: 0 - 16 µs (62.5 kHz)

The module does not provide a power supply for the encoder.

**5.5.6 Mounting/Installation**

When mounted outside the subrack, the ITxx module is inserted on a CPU module PMx or on an ITxx module, already mounted on PMx (using a 96-pin plug connector on the module).

**Spacers**

All of the modules must be screwed to one another using the spacers provided (3 spacers)!

**For the first ITxx**

The first ITxx, mounted directly on a CPU module, must be retained using the **metal spacers** (these are included with the PMx). The electrical contact which is established is required to identify the first expansion module. The metal spacers are attached to the PMX using the M3 screws provided together with the washers and spring washers.

**For a second ITxx**

If only **one ITxx** module is used, it can be screwed to the metal spacers using the M4 nuts (and washers) provided.

If a second ITxx module is used, the first ITxx module is not screwed using the nuts, but instead, using **plastic** spacers (these are included with the ITxx modules).

The second ITxx module can then be inserted on the **plastic** spacers, and screwed together using the M4 nuts (and washers).

After the module assembly has been screwed together, it is inserted into the subrack.

**5.5.7 Application information and noise immunity**

- Operation **without** fans is possible
- Noise immune operation is only possible, if it is tightly screwed into the subrack.

**Other information**

For more detailed information on EMC and the ambient conditions, refer to the "General technical data" section!

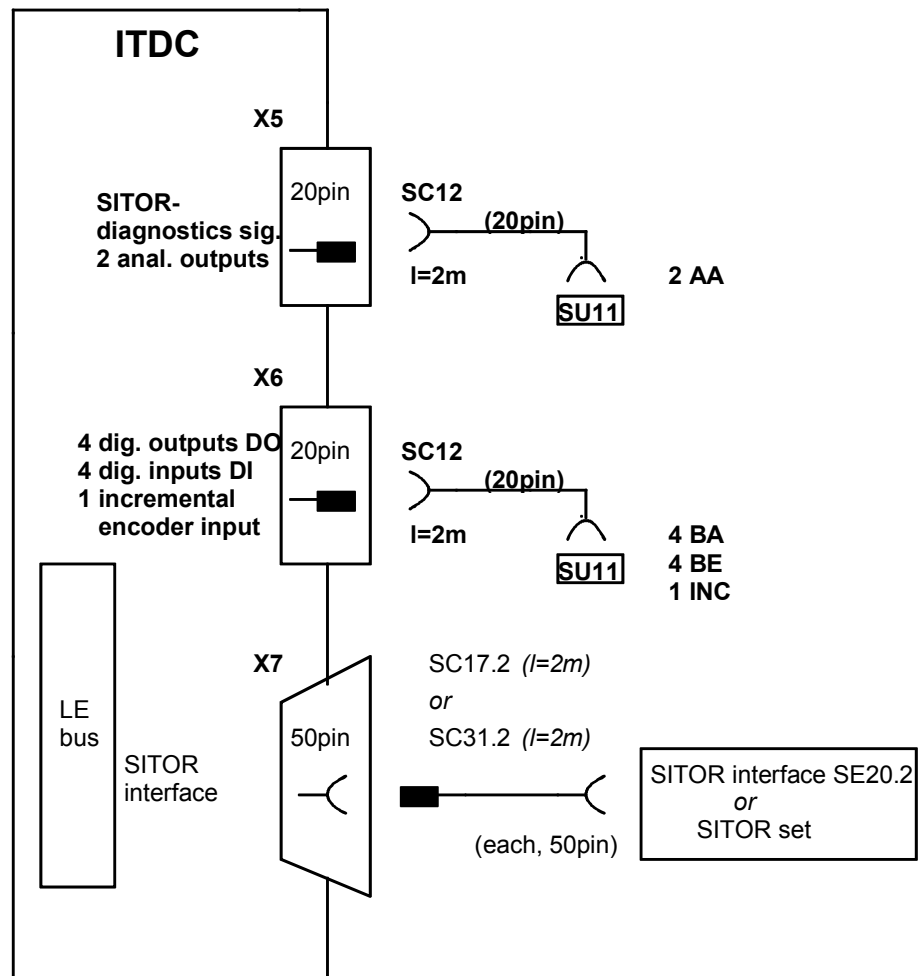
**5.5.8 Connecting diagrams**

Fig. 5-12 Connecting cables and interface modules