

6.1 Communications support modules CS

6.1.1 Communications support module CS7

Order No. 6DD1662-0AB0

Description The CS7 module is a **support module** for the following **communication modules**:

- SS4
- SS5
- SS52

Serial data transfer protocols (DUST, USS, PROFIBUS) can be implemented using the CS7 and the communication modules.

There is a dual port RAM on the CS7, via which the communication modules can transfer data with the CPU modules.

Features

- 3 plug-in receptacle for communication modules (X01 to X03)
- Dual port RAM with 16 Kbytes per communications module
- 2 **diagnostic LEDs** per plug-in compartment (H10/H11, H20/H21 , H30/H31) to display the status of the communications module; the significance of the LED depends on the particular communications module.
- Transfers the L-bus basic sampling time (for synchronization) on the communications module; this function is not used for SS4, SS5, SS52 communication modules.
- Transfers the clock interrupt from the communications module to the CS7 to set the real-time clock of a CPU module; this function is not used for SS4, SS5, SS52 communication modules.
- An interrupt signal on the L bus can be generated from the communications module. However, it must be ensured that only **one** interface module executes this function (configured). This function is not used for SS4, SS5, SS52 communication modules,.
- Test socket pair for each plug-in receptacle (X10/X11, X20/X21, X30/X31) to initiate a reset; only for test purposes! not for operation!
- L-bus connection

Interface to the communications module

The connection between the CS7 support module and the communications modules is established via the 48-pin socket connectors of the 3 plug-in receptacle X01, X02 and X03:

Pin	A	B	C
1	P5	P5	L_LOCK
2	AB1	AB2	AB3
3	AB4	AB5	AB6
4	AB7	AB8	AB9
5	AB10	AB11	AB12
6	L_RESET	CTCLK	AB13
7	DB0	DB1	DB2
8	DB3	DB4	DB5
9	DB6	DB7	DB8
10	DB9	DB10	DB11
11	DB12	DB13	DB14
12	DB15	L_DEN	L_CSMSB
13	L_INTDPR	DT_L_R	L_CSLSB
14	L_RDYDPR	L_LED1	L_LED2
15	P15	N15	L_INTUHR
16	M5	M5	M5

6.1.1.1 Application information and noise immunity

- operation **without fan** is possible
- the **front panels** of the inserted communication modules must be connected to the CS7 front panel using the screen cable supplied!
- slot covers must be provided at empty receptacle.
- noise-immune operation is only possible if the module is tightly screwed into the subrack

Other information Further information on EMC and ambient conditions, refer to Section „General technical data“

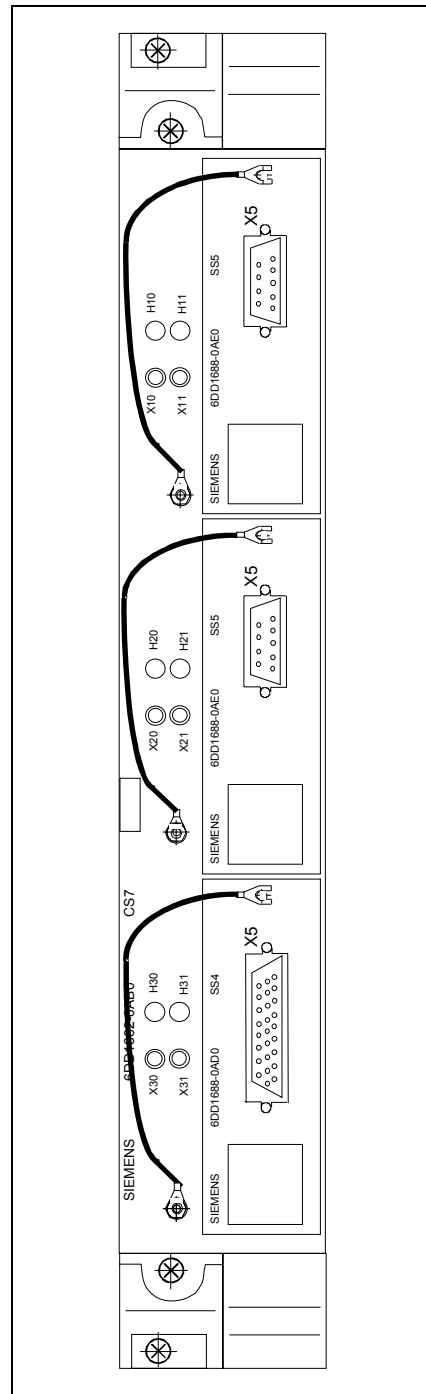

Fig. 6-1 CS7 front panel

6.1.1.2 Technical data

General data

No. of slots occupied	2
Dimensions W x H x D [mm]	40.28 x 233.4 x 220
Weight	Approx. 0.5 kg

Power supply

Rated voltage	min.	max.	Typ. current drain
+5 V	+4.75 V	+5.25 V	0.5 A + current drain of the interface modules
+15 V	+14.4 V	+15.6 V	Current drain of the interface modules
-15 V	-15.6 V	-14.4 V	Current drain of the interface modules

6.1.1.3 Connecting diagram

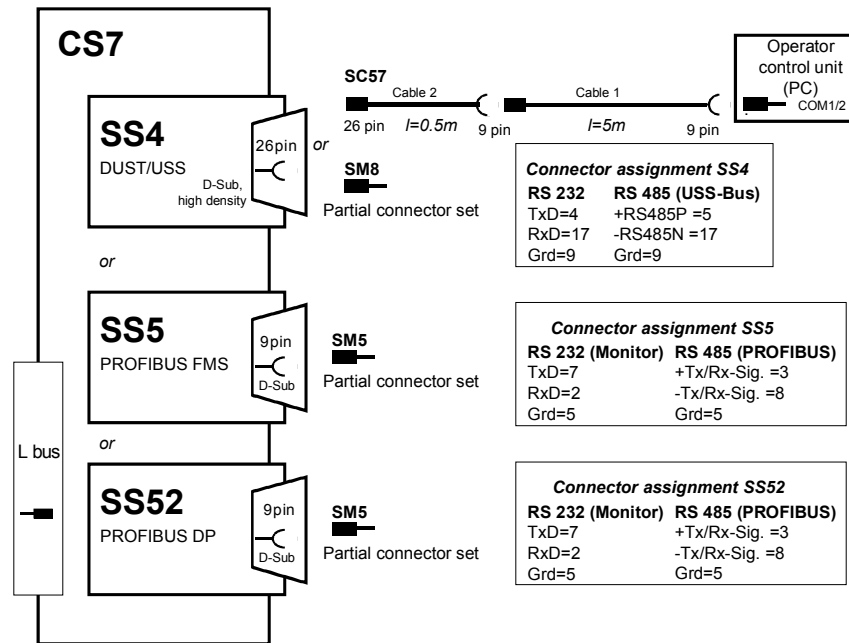

Fig. 6-2 Connecting communication modules and cables

6.1.2 Communications support module CS8

Order No. 6DD1662-0AC0

Description The CS8 module is a **support module** for the following **communication modules**:

- CBP1, CBP2
- CBC, CBD, CBI, CBL

Serial data transfer protocols (CAN, DEVICE-NET, PROFIBUS) can be implemented using CS8 and the communication modules.

Features

- 2 slots (X01, X02) to accept 2 communication modules (COMBOARDS).
- The special covers supplied must be mounted onto the COMBOARDS, so that they are electrically connected and grounded, for EMC-, dust protection- and safety reasons.
- L-bus connection

Interface to the communications module

The connection between the CS8 support module and the communication modules is established via the 64-pin plug connectors of the 2 slots X01 and X02:

Pin-No.	Signal-name	Pin-No.	Signal-name	Pin-No.	Signal-name	Pin-No.	Signal name
A1	N15	A9	D10	A17	M	A25	L_BUSY
B1	N15	B9	D11	B17	P5	B25	L_INT_CU_DPR
A2	M	A10	D12	A18	A8	A26	L_INT_DPR_CU
B2	M	B10	D13	B18	A9	B26	TEMPERATURE
A3	D0	A11	D14	A19	A10	A27	L_DSAVE
B3	D1	B11	D15	B19	A11	B27	ATACHO_DPR
A4	D2	A12	M	A20	A12	A28	BTACHO_DPR
B4	D3	B12	SYNC_DNE	B20	Excitation	B28	P15_OK
A5	D4	A13	NR_TACHO	A21	M	A29	P24_AUX
B5	D5	B13	A1	B21	P5	B29	M24_AUX
A6	D6	A14	A2	A22	L_RD	A30	P15
B6	D7	B14	A3	B22	L_WR	B30	P15
A7	M	A15	A4	A23	L_CS	A31	M
B7	P5	B15	A5	B23	SYNC_TAC	B31	M
A8	D8	A16	A6	A24	M	A32	SINE
B8	D9	B16	A7	B24	L_RESET	B32	COSINE

6.1.2.1 Application information and noise immunity

- Operation **without fans** possible
- The communication modules are screwed to the **PC board** of CS8! The cut-outs of the covers supplied, must be adapted to the connector dimensions of the communication modules.
- The **cover** is mounted between the CS8 and the communications module.
- Free slots must be covered with complete covers.
- Noise-immune operation is only possible if they are screwed into the subrack

Other information

For additional information on EMC and the ambient conditions, refer to Section "General technical data"!

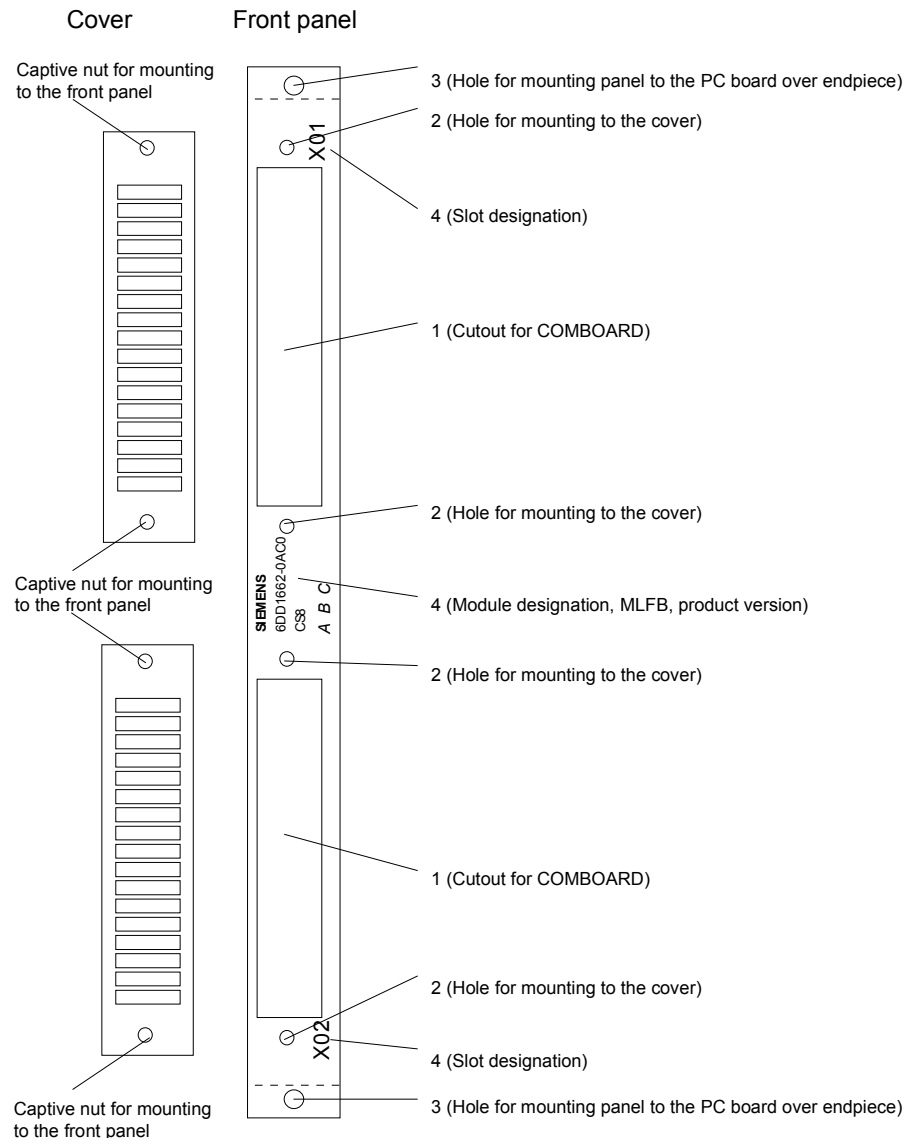

Fig. 6-3 CS8 front panel and cover

6.1.2.2 Technical data

General data

Slot assignment	1
Dimensions W x H x D [mm]	18.3 x 233.4 x 220
Weight	approx. 0.3 kg

Power supply

Rated voltage	min.	max.	Typ. current drain
+5 V	+4.75 V	+5.25 V	0.5 A + current drain of the interface modules
+15 V	+14.4 V	+15.6 V	Current drain of the interface modules
-15 V	-15.6 V	-14.4 V	Current drain of the interface modules

6.1.2.3 Connection diagram

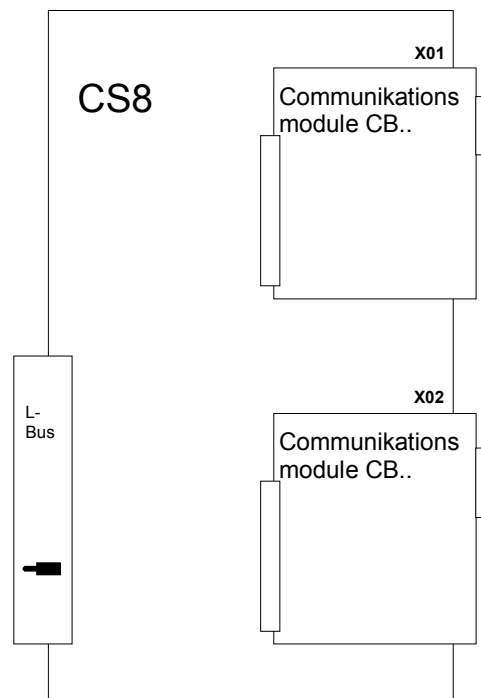

Fig. 6-4 Possibilities of connecting communication modules