

## 5.4 Expansion module IT42

**Order No.** 6DD1606-4AB0

**Description**

The IT42 expansion module provides analog and binary inputs and outputs

The expansion module is inserted on a CPU module (PM5, PM6). A maximum of 2 expansion modules ITxx can be inserted on a CPU module. An ITxx occupies 1 slot (in addition to the mounting slot of the CPU module itself).

**Inputs and outputs**

- 4 analog outputs
- 4 integrating, high-resolution analog inputs (V/fc voltage/frequency conversion)
- 4 analog inputs (ADU)
- 16 binary outputs
- 16 binary inputs

**Block diagram**

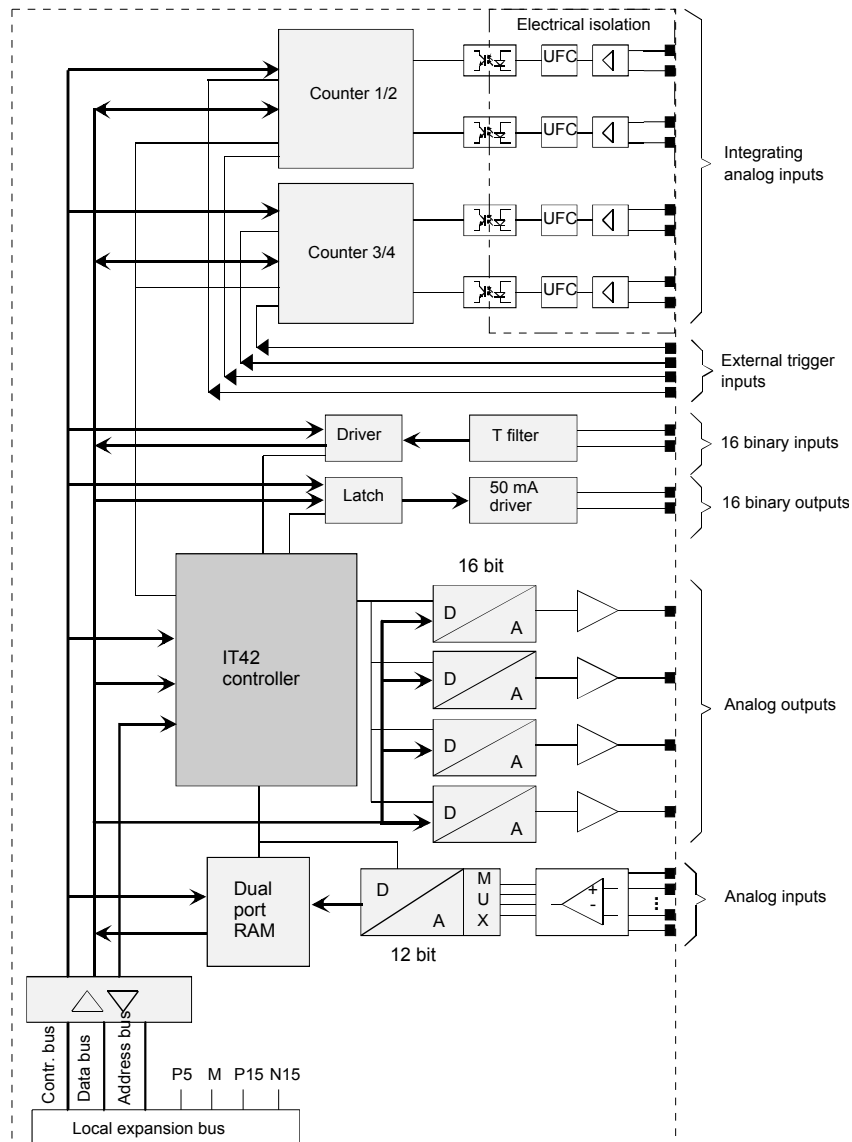

Fig. 5-8 Block diagram of IT42

### 5.4.7 Technical data

#### General data

No. of slots occupied	1
Dimensions W x H x D [mm]	20.14 x 233.4 x 220
Weight	Approx. 0.5 kg

#### Power supply

Rated voltage	min.	max.	Typ. current drain
+5 V	+4.75 V	+5.25 V	420 mA
+15 V	+14.4 V	+15.6 V	450 mA
-15 V	-15.6 V	-14.4 V	140 mA
24 V (external)	20 V	30 V	100 mA + binary output currents

#### Integrating analog inputs

No.	4
Integrating analog inputs	Differential inputs, floating, V/f conversion
Integration time	<ul style="list-style-type: none"> <li>• sampling time of the AFC function block or</li> <li>• the time between 2 positive edges of the external trigger signal</li> </ul>
Input voltage range	-10 V to +10 V
Input resistance	470 kOhm
Input filter	-3 dB transition frequency : 2 kHz
Resolution	Up to 17 bits, depending on the integration time:
	13 bits at 1 ms integration time
	15 bits at 4 ms integration time
	17 bits at 20 ms integration time
Relative accuracy	Typ. 14 bits

#### Sampling analog inputs

No.	4
Type	Differential inputs, non-floating
Input voltage range	-10 V to +10 V
Input resistance	470 kOhm
Input filter	-3 dB transition frequency : 1.5 kHz
Resolution	12 bits
Absolute accuracy	Typ. 10 bits over the complete temperature range
Max. conversion time	45 µs.

**Analog outputs**

No.	4
Type	Output with associated ground, non-floating
Output voltage range	-10 V to +10 V
Output current	+/- 10 mA
Resolution	16 bits
Monotony	14 bits over the complete temperature range
Absolute accuracy	Typ. 13 bits over the complete temperature range
Short-circuit protection to ground	Yes

**Binary inputs**

No.	16 non-floating
Input voltage	24 V DC rated voltage
for 0 signal	-1 V to +6 V or open-circuit inputs
for 1 signal	+13 V to +33 V
Input current	
for 0 signal	0 mA
for 1 signal	3 mA typ.
Delay time for +24 V input signal	50 $\mu$ s

**Binary outputs**

No.	16, non-floating
Power supply voltage	From external
nominal value	24 V DC
perm. range	+20 V to 30 V including ripple
briefly	+35 V, max. 0.5 s
Output current for an 1 signal	
nominal current	50 mA (also corresponds to the max. value)
Short-circuit protection	Electronically and thermally
Limiting inductive switch-off voltages	Supply voltage + 1 V
Residual current	20 $\mu$ A for 0 signal
Signal level	
for 0 signal	Max. 3 V
for 1 signal	Supply voltage - 2.5 V
Switching delay	Max. 15 $\mu$ s