



1756 ControlLogix Power Supplies Specifications

Standard Power Supplies	1756-PA72, 1756-PA72K, 1756-PA75, 1756-PA75K, 1756-PB72, 1756-PB72K, 1756-PB75, 1756-PB75K, 1756-PC75, 1756-PH75
Standard Slim Power Supplies	1756-PA50, 1756-PA50K, 1756-PB50, 1756-PB50K
ControlLogix-XT Power Supplies	1756-PAXT, 1756-PBXT
ControlLogix-XT Slim Power Supplies	1756-PA30XT, 1756-PB30XT
Redundant Power Supplies	1756-PA75R, 1756-PA75RK, 1756-PB75R, 1756-PB75RK
Redundant Power Supplies Chassis Adapter	1756-PSCA2, 1756-PSCA2K
ControlLogix-XT Redundant Power Supplies	1756-PAXTR, 1756-PBXTR
ControlLogix-XT Redundant Power Supplies Chassis Adapter	1756-PSCA2XT
Redundant Power Supply Power Cable	1756-CPR2, 1756-CPR2D, 1756-CPR2U

Topic	Page
Summary of Changes	2
Standard AC Power Supplies	3
Standard DC Power Supplies	6
1756 ControlLogix-XT Power Supplies	9
Redundant Power Supplies	12
Power Load and Transformer Sizing	20
Additional Resources	23

Standard AC Power Supplies

Mounting Dimensions

1756-PA72, 1756-PA72K, 1756-PA75, 1756-PA72K

1756-PA50, 1756-PA50K

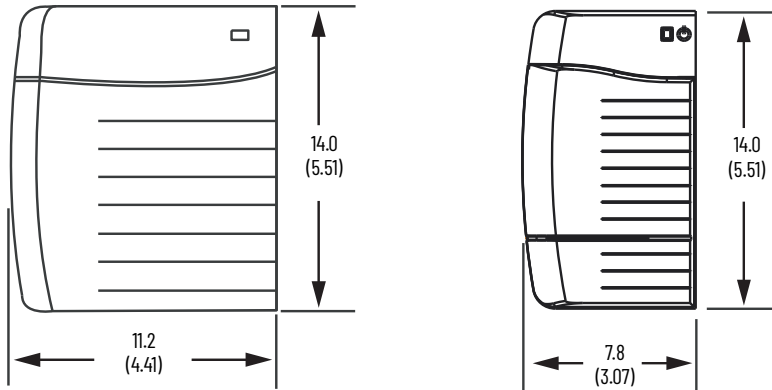

Dimensions are in cm (in.).

Technical Specifications - Standard AC Power Supplies

Attribute	1756-PA50, 1756-PA50K	1756-PA72/C, 1756-PA72K/C	1756-PA75/B, 1756-PA75K/B
Input voltage range ⁽¹⁾	85...265V AC		
Input voltage, nom	120V/240V AC		
Input frequency range	47...63 Hz		
Input power, max	81 W/91VA @ 50 °C (122 °F) 68 W/77VA @ 60 °C (140 °F)	100VA/100 W	
Output power, max	60 W @ 0...50 °C (32...122 °F) ⁽³⁾ 50 W @ 0...60 °C (32...140 °F) ⁽⁴⁾	75 W @ 0...60 °C (32...140 °F) ⁽⁶⁾	
Inrush current, max	20 A		
Hold up time ⁽²⁾	4 cycles @85...265V AC, 50/60 Hz, 60 W 5 cycles @85...265V AC, 50/60 Hz, 50 W	5 cycles @ 85V AC, 50/60 Hz 6 cycles @ 120V AC, 50/60 Hz 6 cycles @ 200V AC, 50/60 Hz 6 cycles @ 240V AC, 50/60 Hz	2 cycles @ 85V AC, 60 Hz 6 cycles @ 120V AC, 60 Hz 20 cycles @ 220V AC, 60 Hz
Current capacity @ 1.2V DC	1.5 A		
Current capacity @ 3.3V DC	2 A	4 A	
Current capacity @ 5.1V DC	8 A @ 50 °C (122 °F) 6 A @ 60 °C (140 °F)	10 A	13 A
Current capacity @ 24V DC	2.5 A @ 50 °C (122 °F) 2.0 A @ 60 °C (140 °F)	2.8 A	
Isolation voltage	250V (continuous), Reinforced Insulation Type, Power Input to Backplane Type tested @ 3150V DC for 60 s	250V (continuous), Reinforced Insulation Type, Power Input to Backplane Type tested at 3500V DC for 60 s	
Weight, approx	0.77 kg (1.7 lb)	0.95 kg (2.10 lb)	
Dimensions (HxWxD), approx	14.0 x 7.8 x 14.5 cm (5.51 x 3.07 x 5.71 in.)	14.0 x 11.2 x 14.5 cm (5.51 x 4.41 x 5.71 in.)	
Module location	Left side of 1756 chassis		
Chassis	1756-A4, 1756-A7, 1756-A10, 1756-A13, 1756-A17		
Chassis compatibility	Series A Series B Series C	Series B Series C	
Wire size	2.5 mm ² (14 AWG) solid or stranded copper wire that is rated at 90 °C (194 °F), or greater, 1.2 mm (3/64 in.) insulation max		
Wire category	1 - on power ports ⁽⁵⁾		

Technical Specifications - Standard AC Power Supplies (Continued)

Attribute	1756-PA50, 1756-PA50K	1756-PA72/C, 1756-PA72K/C	1756-PA75/B, 1756-PA75K/B
Conductor screw torque	0.565 N•m (5 lb•in)		
North American temperature code	T4		
Enclosure type rating	None (open-style)		

- (1) UL certification for 120/240V AC, 50/60 Hz nominal. Rockwell Automation specified 85...265V AC, 47...63 Hz.
- (2) The hold up time is the time between input voltage removal and DC power failure.
- (3) The combination of all output power (5.1V backplane, 24V backplane, 3.3V backplane, and 1.2V backplane) can't exceed 60 W @ 50 °C (122 °F) maximum temperature.
- (4) The combination of all output power (5.1V backplane, 24V backplane, 3.3V backplane, and 1.2V backplane) can't exceed 50 W @ 60 °C (140 °F) maximum temperature.
- (5) Use this conductor category information to plan conductor routing as described in the system level installation manual. See the Industrial Automation Wiring and Grounding Guidelines, publication [1770-4.1](#).
- (6) The combination of all output power (5.1V backplane, 24V backplane, 3.3V backplane, and 1.2V backplane) can't exceed 75 W.

Environmental Specifications - Standard AC Power Supplies

Attribute	1756-PA50, 1756-PA50K	1756-PA72/C, 1756-PA72K/C, 1756-PA75/B, 1756-PA75K/B
Temperature, operating IEC 60068-2-1 (Test Ae, Operating Cold), IEC 60068-2-2 (Test Be, Operating Dry Heat), IEC 60068-2-14 (Test Nb, Operating Thermal Shock)	0 °C < Ta < +60 °C (32 °F < Ta < 140 °F)	
Temperature, surrounding air, max	60 °C (140 °F)	
Temperature, nonoperating IEC 60068-2-1 (Test Ab, Unpackaged Nonoperating Cold), IEC 60068-2-2 (Test Bb, Unpackaged Nonoperating Dry Heat), IEC 60068-2-14 (Test Na, Unpackaged Nonoperating Thermal Shock)	-40...+85 °C (-40...+185 °F)	
Relative humidity IEC 60068-2-30 (Test Db, Unpackaged Damp Heat)	5...95% noncondensing	
Vibration IEC 60068-2-6 (Test Fc, Operating)	2 g @ 10...500 Hz	
Shock, operating IEC 60068-2-27 (Test Ea, Unpackaged Shock)	30 g	
Shock, nonoperating IEC 60068-2-27 (Test Ea, Unpackaged Shock)	50 g ⁽¹⁾	
Emissions	IEC 61000-6-4	
ESD immunity IEC 61000-4-2	6 kV contact discharges 8 kV air discharges	
Radiated RF immunity IEC 61000-4-3	10V/m with 1 kHz sine wave 80% AM from 80...2000 MHz 10V/m with 200 Hz 50% Pulse 100% AM @ 900 MHz 10V/m with 200 Hz 50% Pulse 100% AM @ 1890 MHz 3V/m with 1 kHz sine wave 80% AM from 2000...2700 MHz	
EFT/B immunity IEC 61000-4-4	±4 kV at 5 kHz on power ports	
Surge transient immunity IEC 61000-4-5	±1 kV line-line (DM) and ±2 kV line-earth (CM) on power ports	
Conducted RF immunity IEC 61000-4-6	10V rms with 1 kHz sine wave 80% AM from 150 kHz...80 MHz	
Voltage variation IEC 61000-4-11	30% dips for 1 period at 0° and 180° on AC supply ports 60% dips for 5 and 50 periods on AC supply ports ±10% fluctuations for 15 min on AC supply ports >95% interruptions for 250 periods on AC supply ports	
Damped oscillatory wave immunity IEC 61000-4-18	±2.5 kV line-line (DM) and ±2.5 kV line-earth (CM) on power ports	-

- (1) Series C chassis have a maximum nonoperating shock value of 30 g. If you select a Series C chassis for use with your power supply, you're limited to a maximum nonoperating shock value of 30 g.

Certifications - Standard AC Power Supplies

Certification ⁽¹⁾	1756-PA50, 1756-PA50K	1756-PA72/C, 1756-PA72K/C	1756-PA75/B, 1756-PA75K/B	
UL	-	UL Listed Industrial Control Equipment. See UL File E65584.		
c-UL-us	UL Listed Industrial Control Equipment, which is certified for US and Canada. See UL File E65584. UL Listed for Class I, Division 2 Group A,B,C,D Hazardous Locations, which are certified for U.S. and Canada. See UL File E194810.	-		
UKCA	In conformity with the following UK Statutory Instruments and their amendments: <ul style="list-style-type: none"> • 2016 No. 1091, Electromagnetic Compatibility Regulations • 2016 No. 1101, Electrical Equipment (Safety) Regulations • 2016 No. 1107, Equipment and Protective Systems Intended for Use in Potentially Explosive Atmospheres Regulations • 2012 No. 3032, Restriction of the Use of Certain Hazardous Substances in Electrical and Electronic Equipment 			
CSA	-	CSA Certified Process Control Equipment. See CSA File LR54689C. CSA Certified Process Control Equipment for Class I, Division 2 Group A,B,C,D Hazardous Locations. See CSA File LR69960C.		
FM	FM Approved Equipment for use in Class I Division 2 Group A,B,C,D Hazardous Locations			
CE	European Union 2014/30/EU EMC Directive, compliant with: <ul style="list-style-type: none"> • EN 61326-1; Meas./Control/Lab., Industrial Requirements • EN 61000-6-2; Industrial Immunity • EN 61000-6-4; Industrial Emissions • EN 61131-2; Programmable Controllers (Clause 8, Zone A & B) European Union 2014/35/EU LVD, compliant with: <ul style="list-style-type: none"> • EN 61010-2-201; Control Equipment Safety Requirements 	European Union 2014/30/EU EMC Directive, compliant with: <ul style="list-style-type: none"> • EN 61326-1; Meas./Control/Lab., Industrial Requirements • EN 61000-6-2; Industrial Immunity • EN 61000-6-4; Industrial Emissions • EN 61131-2; Programmable Controllers (Clause 8, Zone A & B) European Union 2014/35/EU LVD, compliant with: <ul style="list-style-type: none"> • EN 61131-2; Programmable Controllers (Clause 11) 		
RCM	Australian Radiocommunications Act, compliant with: <ul style="list-style-type: none"> • EN 61000-6-4; Industrial Emissions 			
KC	Korean Registration of Broadcasting and Communications Equipment, compliant with: <ul style="list-style-type: none"> • Article 58-2 of Radio Waves Act, Clause 3 			
EAC	Russian Customs Union TR CU 020/2011 EMC Technical Regulation Russian Customs Union TR CU 004/2011 LV Technical Regulation			
CCC	CCC 202012230911830, 202012230911998, 2020122309113868 CNCA-C23-01 强制性产品认证实施规则 防爆电气 CNCA-C23-01 CCC Implementation Rule Explosion-Proof Electrical Products			

(1) See the Product Certification link at rok.auto/certifications for Declarations of Conformity, Certificates, and other certification details.