

CHAPTER 2 - SYSTEM DESCRIPTION

4. FOUR CHANNEL CONTROL CARDS

4.1 General

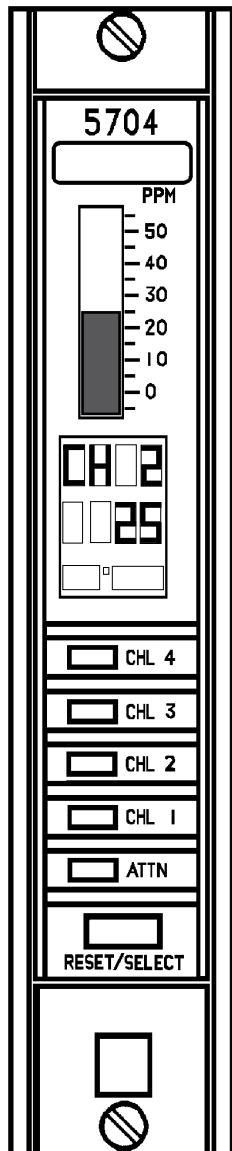

The 5704 Four Channel Control Card provides control, display and alarm facilities for up to four connected gas detectors. The front panel backlit display indicates the gas reading, channel status and channel number while LEDs are used for alarms. A push-button is provided for resetting the alarms and selecting the card for use with the Engineering Card.

The operation of the control card is microprocessor controlled and is fully definable for a wide range of connected gas detectors and application requirements. The software configuration setup is stored in an EEPROM.

There are two types of control card depending on the type of gas detector being fitted to the system:

- a. Four Channel Control Card Catalytic Input
Part Number 05704-A-0144.
- b. Four Channel Control Card 4 - 20mA Input
Part Number 05704-A-0145.

Optional Analogue Output Modules which provide a remote output of the channel card readings can be plugged into the Four Channel Control Card. One module is required per channel and different module types are available to permit either current source or current sink as required.

CHAPTER 2 - SYSTEM DESCRIPTION

4.2 Control Functions

The Four Channel Control Card carries out the control functions for up to four loops of gas detection as follows:

- a. Provides the necessary voltages and currents to drive the connected sensors.
- b. Processes the incoming sensor signals.
- c. Displays the signal levels, one at a time, on the front panel liquid crystal display.
- d. Compares each channel signal level with pre-defined alarm limits.
- e. When the pre-defined alarm limits are exceeded, raises the alarms by lighting up front panel LEDs and operating connected relays.
- f. Informs other cards with the alarm status information.
- g. Self validates the operation of its circuit components, software operation and the condition of the sensor.

4.3 Analogue Output Module

Optional Analogue Output Modules may be factory fitted to the Four Channel Control Card and are used on each channel of gas detection to provide a current loop output which follows the sensor signal level. This may be set electronically to produce a 0 - 20mA output or a 4 - 20mA output and can be used to operate a chart recorder, data logger, PLC, etc. Two versions are available:

- a. Analogue Output Module, Current Sink
Part Number 04200-A-0145
- b. Analogue Output Module, Current Source
Part Number 04200-A-0146

CHAPTER 2 - SYSTEM DESCRIPTION

4.4 Physical Layout

The physical layout of the Four Channel Control Card is shown below. Analogue Output Modules, when fitted, plug into channel sockets as shown:

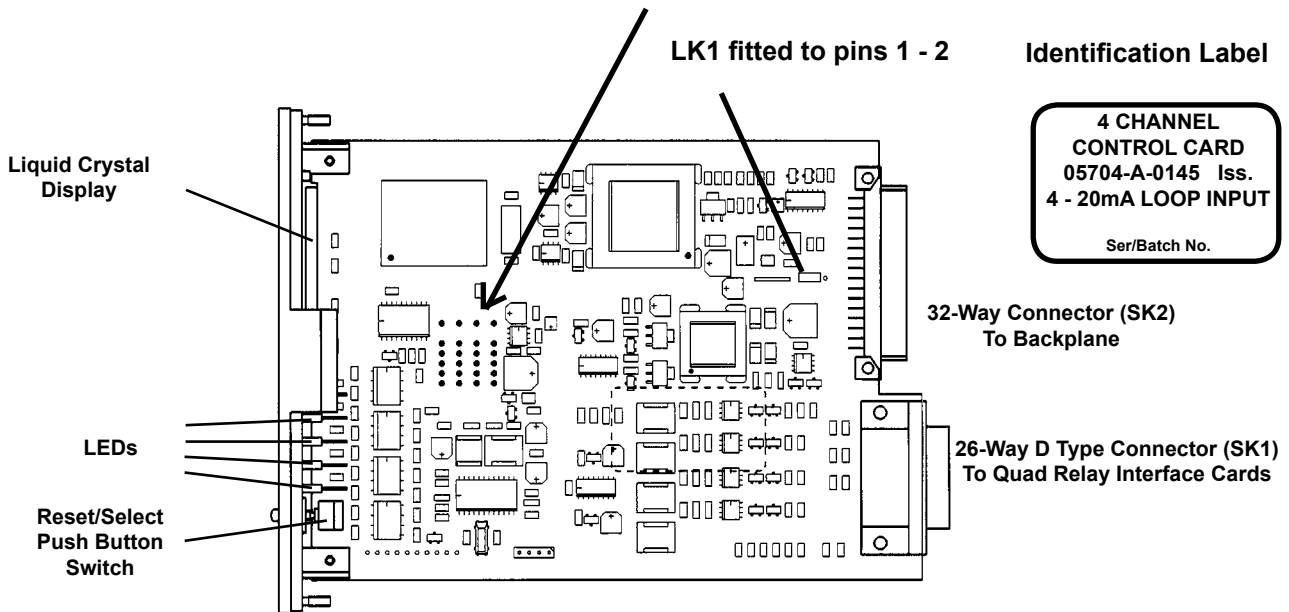
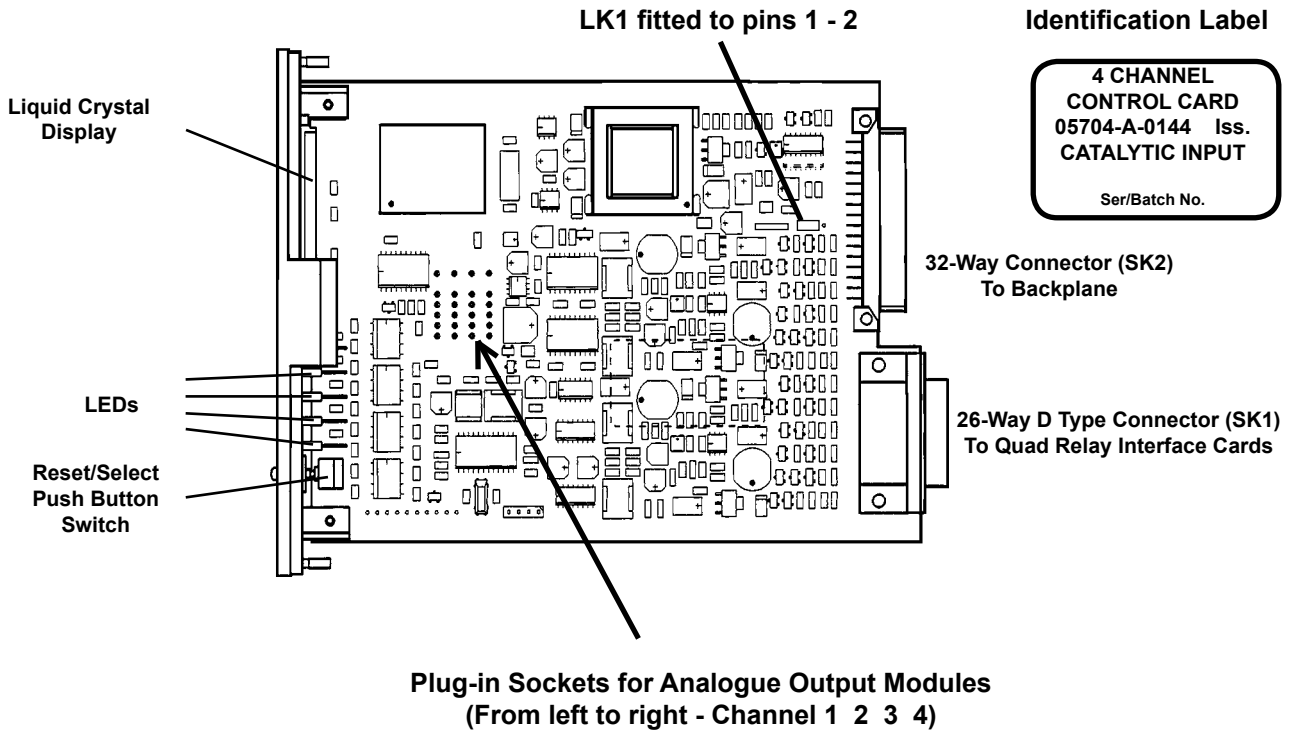

CHAPTER 2 - SYSTEM DESCRIPTION

5. QUAD RELAY INTERFACE CARD AND RELAY INTERFACE ASSEMBLY

5.1 General

The Quad Relay Interface Card provides the interface between a Four Channel Control Card and the field wiring.

An Expansion Relay Card can also be factory fitted to the Quad Relay Interface Card and the resultant assembly is then known as the Relay Interface Assembly. This assembly is used to expand the standard four relays available for alarms on the Quad Relay Interface to 16 relays.

5.2 Quad Relay Interface Card (Part Number 05704-A-0121)

5.2.1 General

Provides connections between the four sensors and the control card. In addition, four single pole relays provide voltage free contact outputs that can be configured for the A1 alarm level, A2 alarm level, A3 alarm level, fault or inhibit conditions and as individual alarms or master alarms. Connections for power, remote inputs and analogue outputs are also provided.

The front and rear access connections are shown in Sections 5.2.2 and 5.2.3 respectively while the physical layout is shown below:

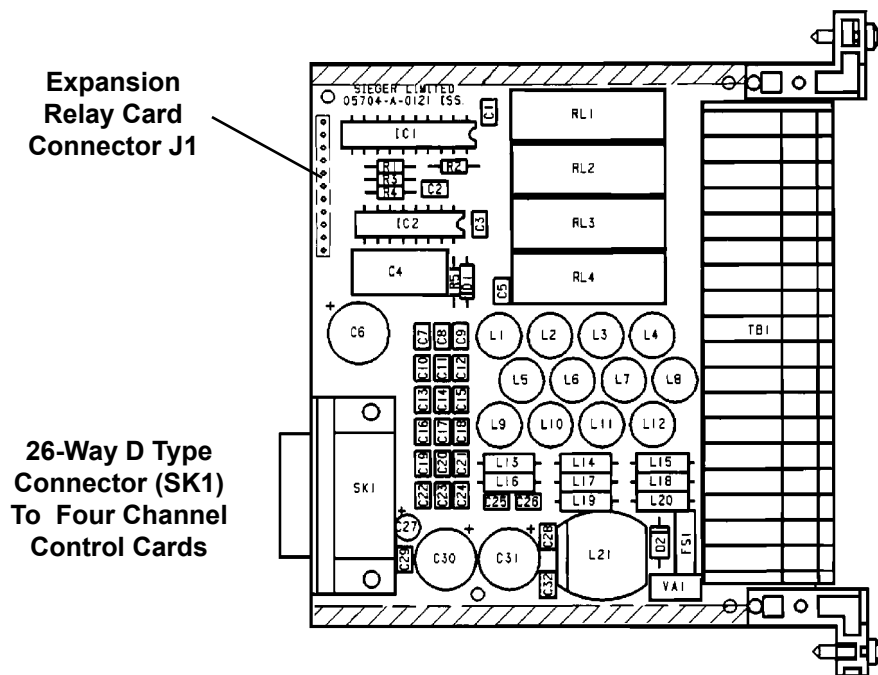

CHAPTER 2 - SYSTEM DESCRIPTION

5.2.2 Quad Relay Card Rear Access Connections

RL1-NC (Master Fault) 1 2 RL1-NO (Master Fault)

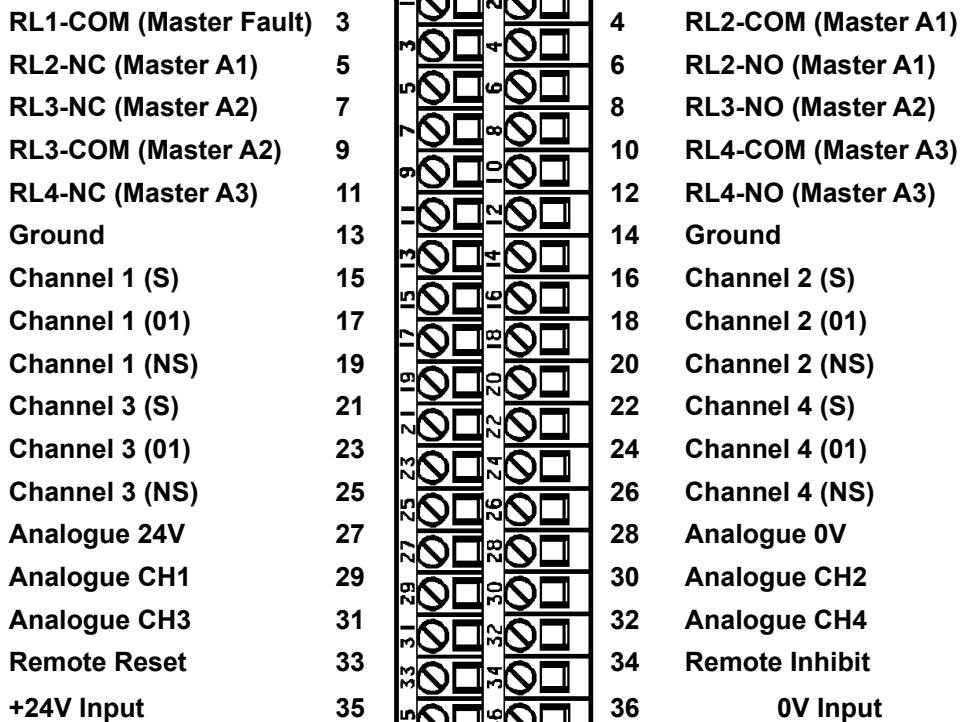

1. NC = Normally Closed. NO = Normally Open. COM = Common.
2. Relay contact conditions refer to the no power state of the relay.
3. The functions shown for terminals 1 to 12 are the default functions for relays RL1 to RL4 only. For other configurations - refer to the configuration printout.

CHAPTER 2 - SYSTEM DESCRIPTION

5.2.3 Quad Relay Card Front Access Connections

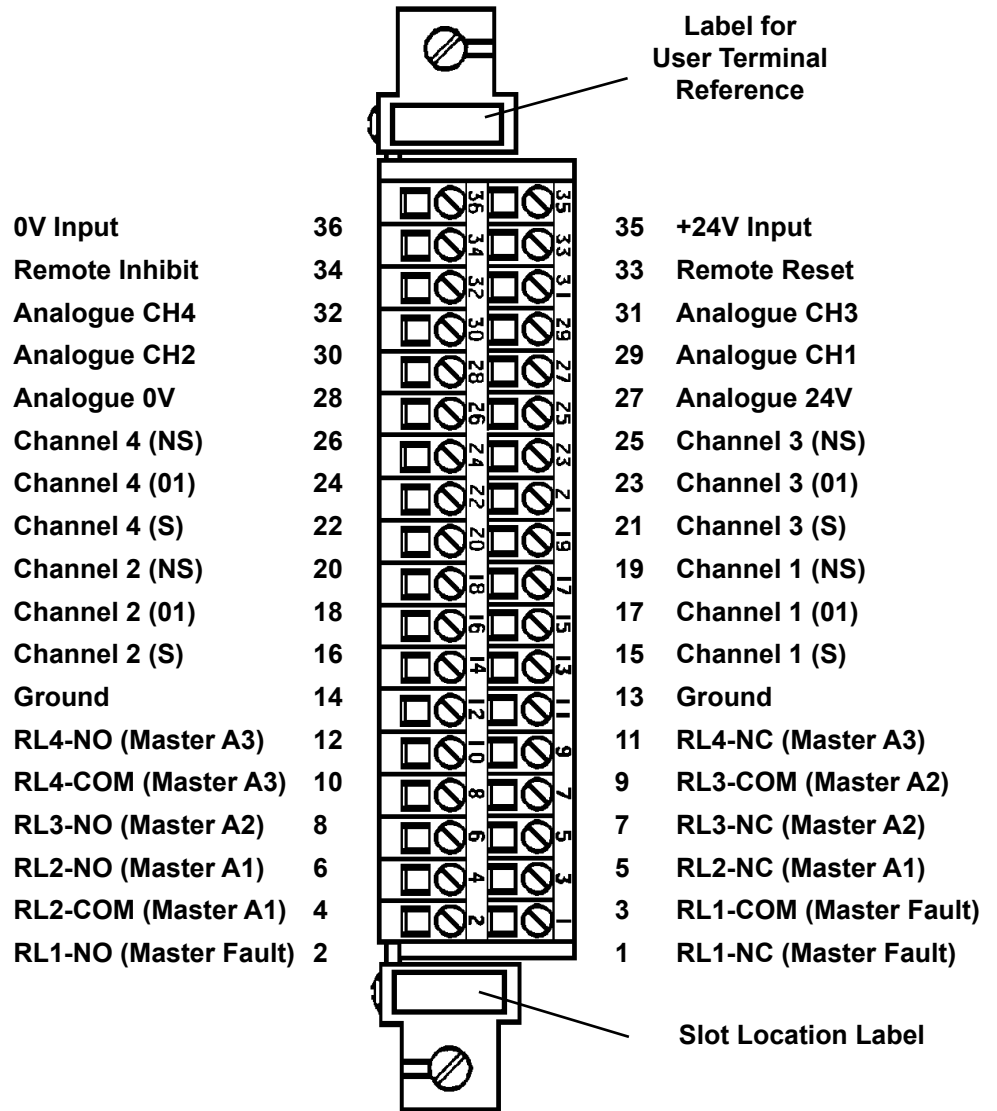

1. NC = Normally Closed. NO = Normally Open. COM = Common.
2. Relay contact conditions refer to the no power state of the relay.
3. The functions shown for terminals 1 to 12 are the default functions for relays RL1 to RL4 only. For other configurations - refer to the configuration printout.

CHAPTER 2 - SYSTEM DESCRIPTION

5.3 Relay Interface Assembly (Part Number 05704-A-0131)

5.3.1 General

The following diagrams show the Expansion Relay Card fitted to the Quad Interface Relay Card to form a Relay Interface Assembly:

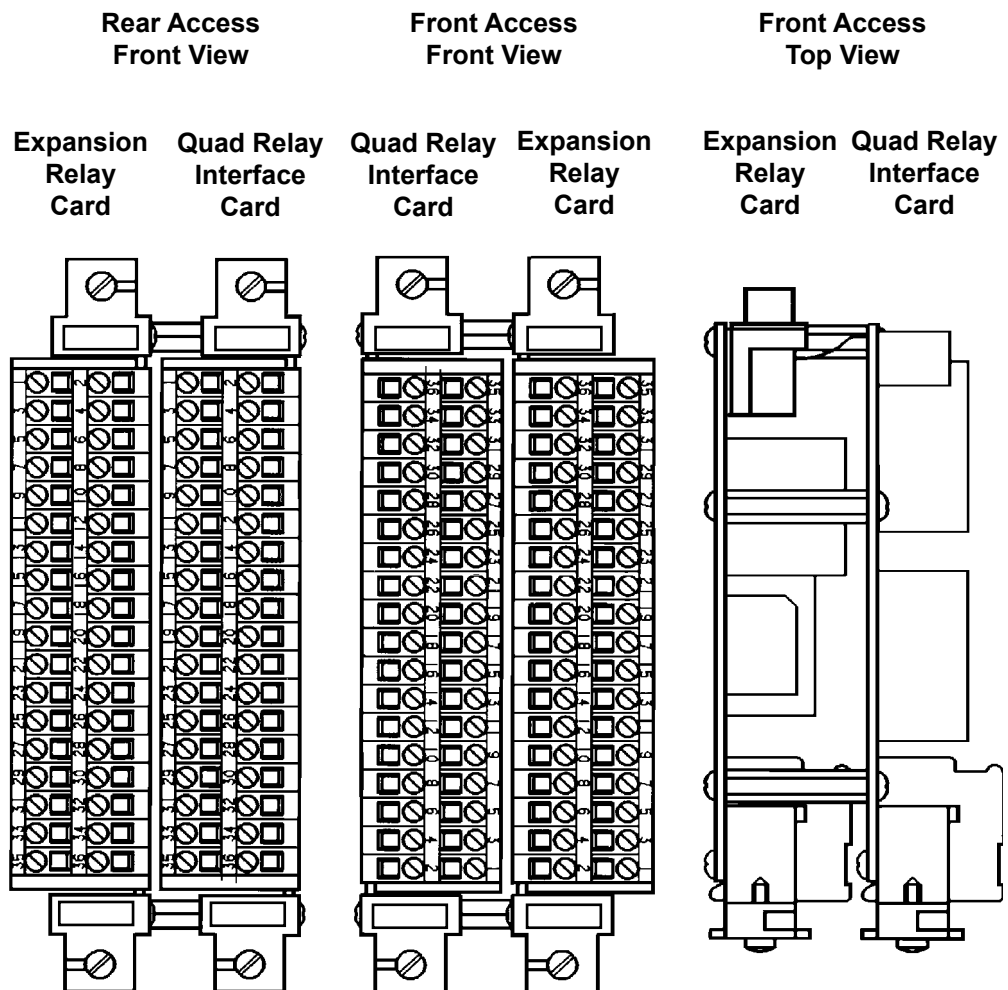

1. For details of the Quad Interface Card, see Section 5.2.
2. For details of the Expansion Relay Card, see Sections 5.4.

CHAPTER 2 - SYSTEM DESCRIPTION

5.3.2 Relay Interface Assembly Rear Access Connections

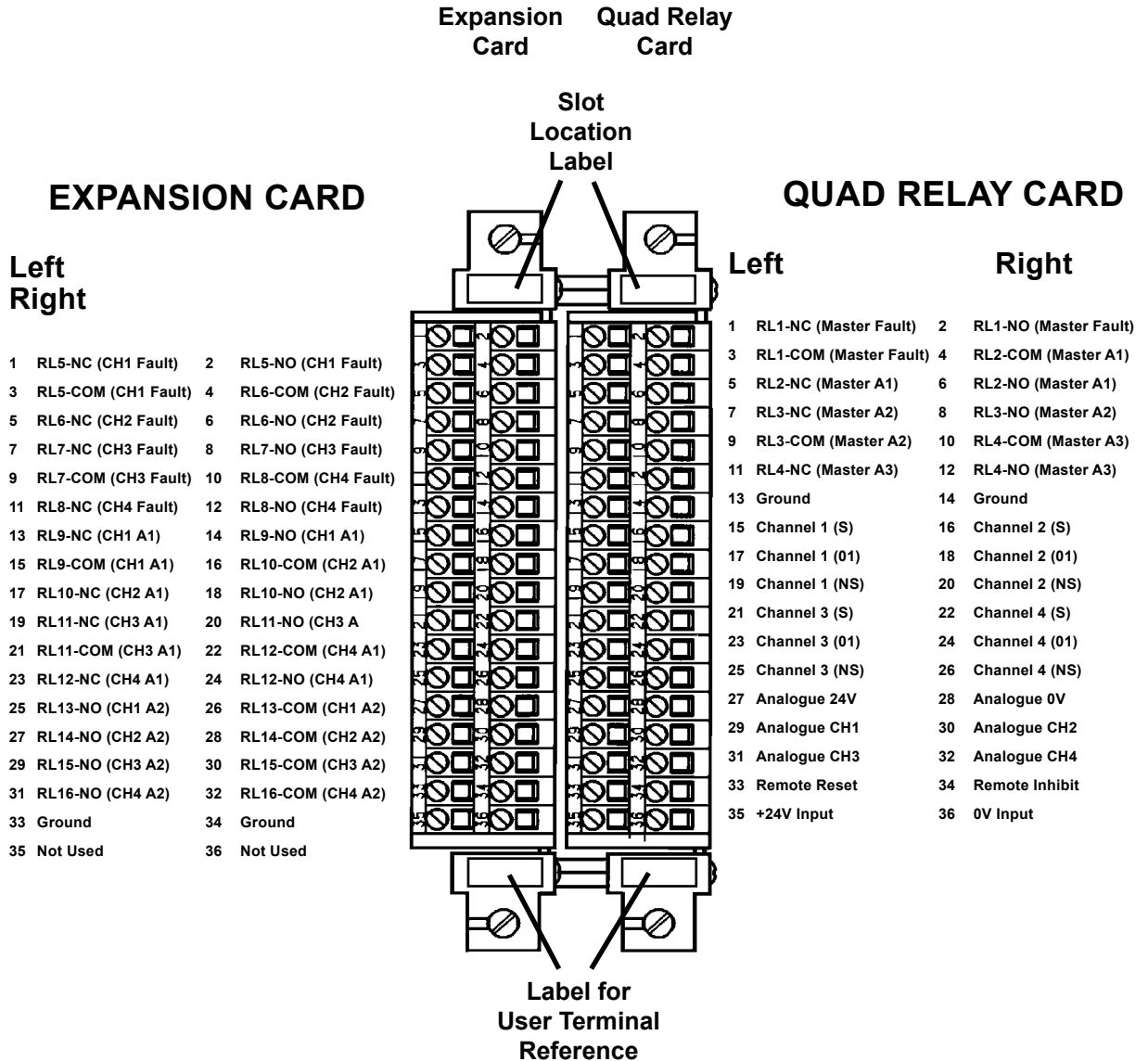

1. NC = Normally Closed. NO = Normally Open. COM = Common.
2. Relay contact conditions refer to the no power state of the relay.

CHAPTER 2 - SYSTEM DESCRIPTION

5.3.3 Relay Interface Assembly Front Access Connections

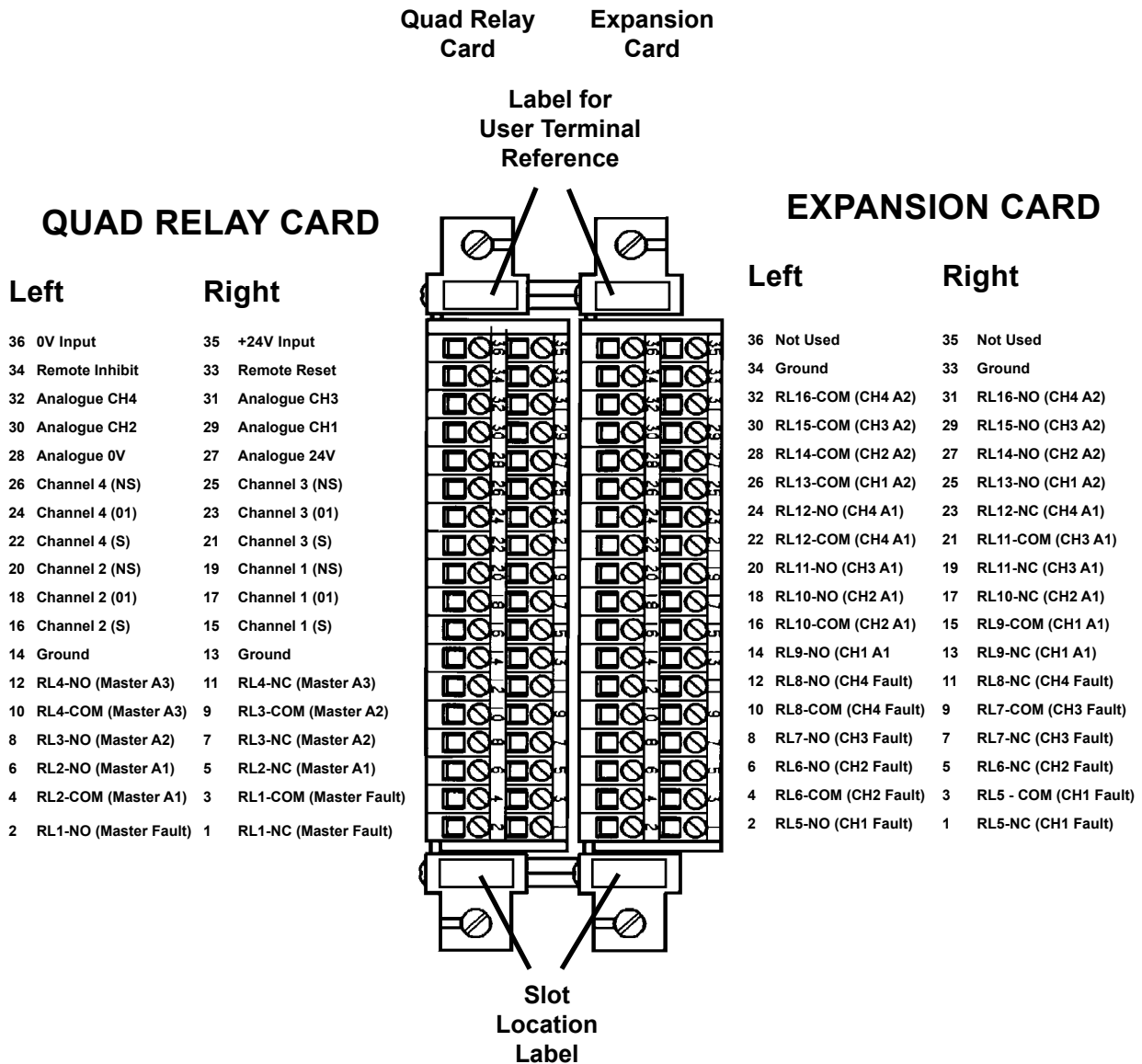

1. NC = Normally Closed. NO = Normally Open. COM = Common.
2. Relay contact conditions refer to the no power state of the relay.

CHAPTER 2 - SYSTEM DESCRIPTION

5.4 Expansion Relay Card

The Expansion Relay Card provides relay expansion for a Four Channel Control Card and the Quad Relay Interface Card. The Expansion Relay Card is connected to the Quad Relay Interface Card and provides 12 additional relays, eight of which are single pole changeover and four are single pole single throw. The relays can be configured for A1, A2, A3, fault or inhibit alarms and as individual or master outputs.

When the Expansion Relay Card is connected to the Quad Relay Interface Card, the pair of cards take up two slots of the rack. For this reason a blank panel has to be fitted to the rack front panel adjacent to the associated Four Channel Control Card.

The front and rear access connections are shown in Sections 5.3.2 and 5.3.3 respectively while the physical layout is shown below:

