

Low voltage electrical distribution

# Micrologic

Control units

2.0 A, 5.0 A, 6.0 A, 7.0 A

2.0 E, 5.0 E, 6.0 E

User manual

11/2011



Discover the  
new Micrologic E  
control unit!



**Schneider**  
Electric

All Compact NS630-3200, Masterpact NT and Masterpact NW circuit breakers are equipped with a Micrologic control unit that can be changed on site. The control units are designed to protect power circuits and connected loads.

## Micrologic 2.0 E

X  
Y  
Z

- X: type of protection**
- 2 for basic protection
  - 5 for selective protection
  - 6 for selective + ground-fault protection
  - 7 for selective + earth-leakage protection.

**Y: version number**  
identification of the control-unit generation. "0" signifies the first generation.

- Z: type of measurement**
- A for "ammeter"
  - E for "energy meter"
  - P for "power meter"
  - H for "harmonic meter"
  - no indication: no measurements

**Note:** In this document, A/E signifies A or E when characteristics are common to both Micrologic A and Micrologic E control units.

### Micrologic 2.0 A and 2.0 E: basic protection

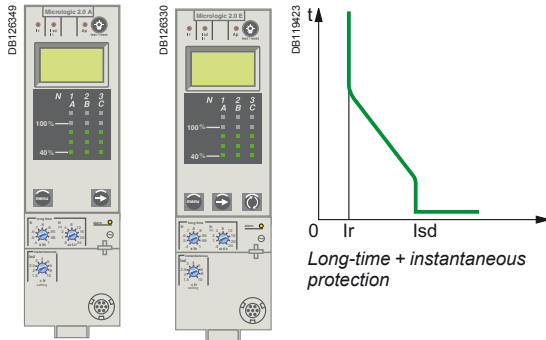

Micrologic 2.0 A Micrologic 2.0 E

### Micrologic 5.0 A and 5.0 E: selective protection

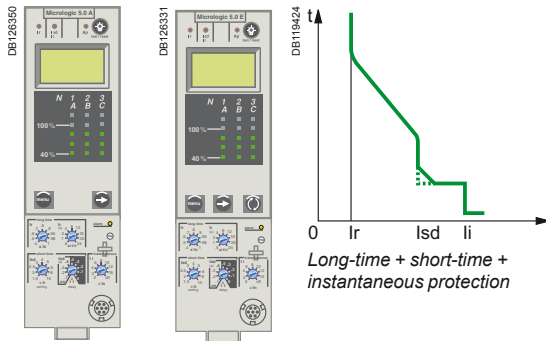

Micrologic 5.0 A Micrologic 5.0 E

### Micrologic 6.0 A and 6.0 E: selective + ground-fault protection

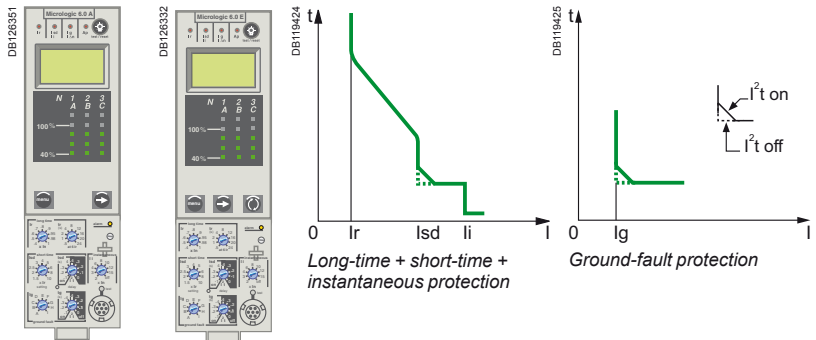

Micrologic 6.0 A Micrologic 6.0 E

### Micrologic 7.0 A: selective + earth-leakage protection

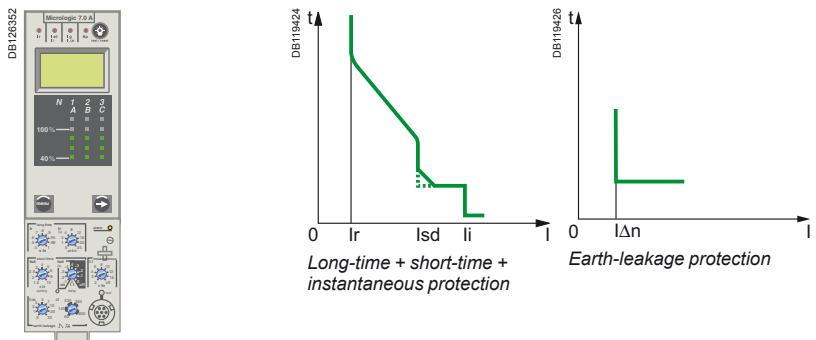

Micrologic 7.0 A

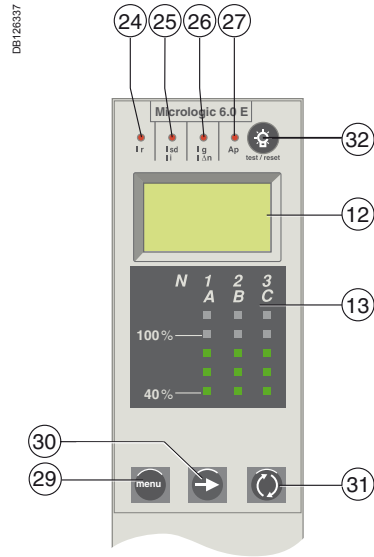
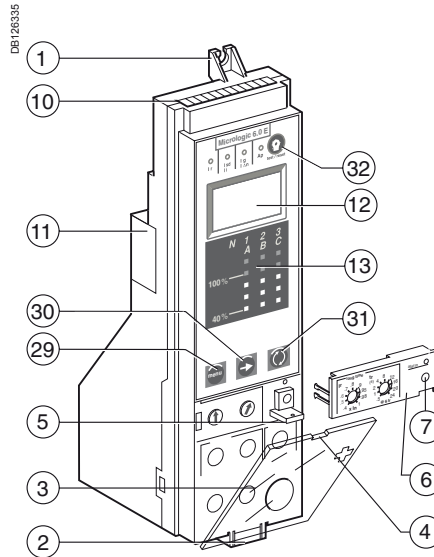
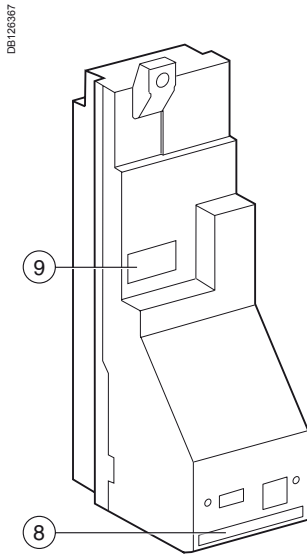

- 1 top fastener
- 2 bottom fastener
- 3 protective cover
- 4 cover opening point
- 5 lead-seal fixture for protective cover
- 6 long-time rating plug
- 7 screw for long-time rating plug
- 8 connection with circuit breaker
- 9 infrared link with communication interfaces
- 10 terminal block for external connections
- 11 battery compartment
- 12 digital display
- 13 three-phase bargraph and ammeter

**Adjustment dials**

- 14 long-time current setting  $I_r$
- 15 long-time tripping delay  $t_r$
- 16 short-time pickup  $I_{sd}$
- 17 short-time tripping delay  $t_{sd}$
- 18 instantaneous pick-up  $I_{sd}$
- 19 instantaneous pick-up  $I_i$
- 20 ground-fault pick-up  $I_g$
- 21 ground-fault tripping delay  $t_g$
- 22 earth-leakage pick-up  $I_{\Delta n}$
- 23 earth-leakage tripping delay  $\Delta t$

**Indications**

- 24 LED indicating long-time tripping
- 25 LED indicating short-time tripping
- 26 LED indicating ground-fault or earth-leakage tripping
- 27 LED indicating auto-protection tripping
- 28 LED indicating an overload

**Navigation**

- 29 menu selection button
- 30 menu scroll button
- 31 "Quick View" navigation button (Micrologic E only)
- 32 fault-trip reset and battery test button

**Test**

- 33 test button for ground-fault and earth-leakage protection
- 34 test connector

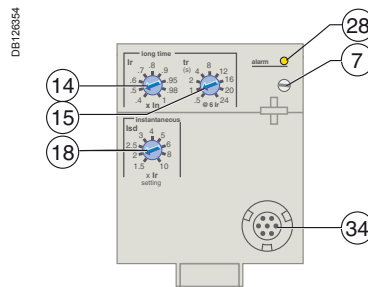

Micrologic 2.0 A/E

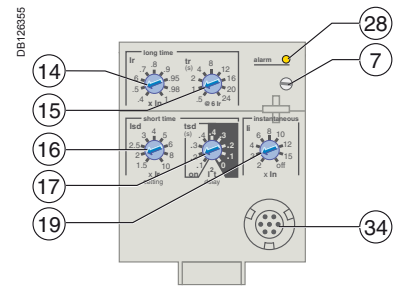

Micrologic 5.0 A/E

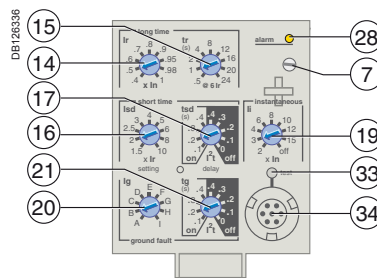

Micrologic 6.0 A/E

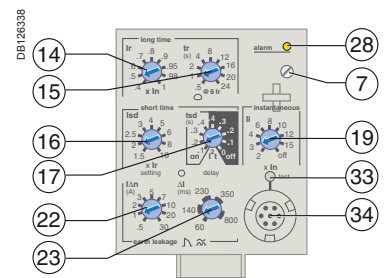

Micrologic 7.0 A

All Micrologic A and Micrologic E control units are equipped with overload and fault indication LEDs.

### Overload LED

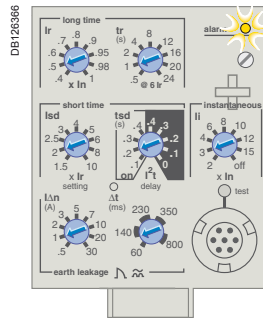

This LED signals that the long-time current setting  $I_r$  has been overrun.

### Fault indications

#### Important

The battery maintains the fault indications. If there are no indications, check the battery.

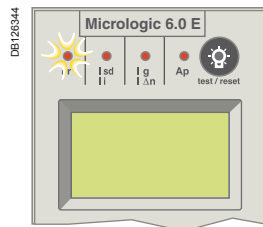

Signals tripping due to overrun of the long-time current setting  $I_r$ .

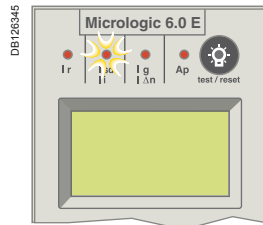

Signals tripping due to overrun of the short-time pick-up  $I_{sd}$  or instantaneous pick-up  $I_{sd}$  or  $I_i$ .

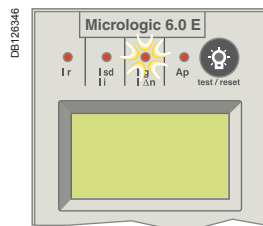

Signals tripping due to overrun of the ground-fault pick-up  $I_g$  or earth-leakage pick-up  $I_{\Delta n}$ .

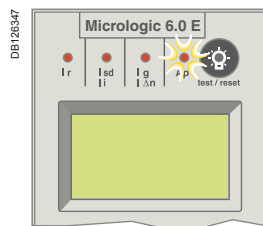

Signals tripping due to the auto-protection function of the control unit.

The auto-protection function (excessive temperature or short-circuit higher than circuit-breaker capacity) opens the circuit breaker and turns on the  $A_p$  LED.

#### Important

If the circuit breaker remains closed and the  $A_p$  LED remains on, contact the Schneider Electric after-sales support department.

Micrologic E control units let you access information that can be used to analyse or avoid circuit breaker tripping, thereby increasing the overall availability of your installation. Available information includes the trip history and tripping pre-alarms.

### Trip history

The trip history displays the list of the last 10 trips. For each trip, the following indications are recorded and displayed:

- the tripping cause: Ir, Isd, li, Ig or Auto-protection (Ap) trips
- the date and time of the trip (requires communication option) in order to set Date and Time.

- List of trip causes:
- overloads (Ir)
  - short-circuits (Isd or li)
  - ground faults (Ig)
  - auto-protection (Ap).

The trip history display is presented on page 28.

### Pre-alarms

#### Definition

Micrologic E control units can be set to deliver pre-alarms via their optional M2C contacts (see page 38). These pre-alarms can be used to warn operators that the current is approaching a trip threshold. In this way, remedial measures (e.g. load-shedding, maintenance, etc.) can be taken before the circuit breaker trips, avoiding unnecessary shutdowns.

- Two types of pre-alarms are available, depending on the control unit.
- Long-time protection pre-alarm: all Micrologic E control units can be set to deliver a pre-alarm via one of their two outputs when the current reaches 90 % of the long-time protection current setting Ir.
  - Ground-fault protection pre-alarm: Micrologic 6.0 E control units can also be set to deliver a pre-alarm via one of their two outputs when the current reaches 90 % of the ground-fault protection pickup Ig. Both Ir and Ig pre-alarms can be implemented if neither of the two outputs are required for other functions.

See page 32 for general information on output settings (M2C contacts) or page 35 for an example of how to set an output to implement these or other functions.

#### Operation

The Ir and Ig pre-alarms are delivered via the non-latching outputs (M2C contacts) of Micrologic E control units.

- Pickup (pre-alarm activation): when the current exceeds the pickup threshold (equal to 90 % of the Ir current setting or Ig pickup), the output state changes from 0 to 1 after a time delay of 1 second.
- Dropout (pre-alarm deactivation): when the current falls below the dropout threshold (equal to 85 % of the Ir current setting or Ig pickup), the output state returns to 0 after a non-adjustable time delay of 1 second and the pre-alarm is automatically deactivated.

	Pickup (pre-alarm activation)		Dropout (pre-alarm deactivation)	
	Threshold	Time delay	Threshold	Time delay
Ir pre-alarm	90 % of Ir	1 s	85 % of Ir	1 s
Ig pre-alarm	90 % of Ig	1 s	85 % of Ig	1 s

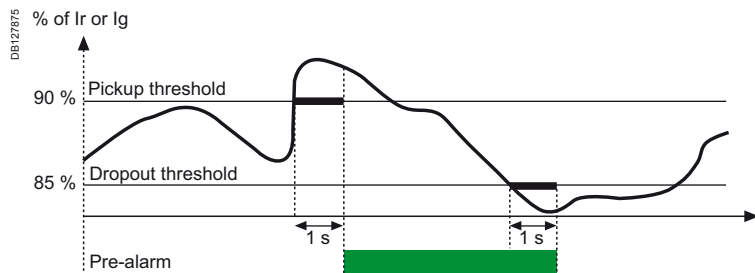

# Tree Navigation mode

## Micrologic E menu display

The figures below show all the screens of the 2 Micrologic E **navigation trees** with all details concerning screen content and navigation between the various branches and screens of the trees.

Display tree branches	Screens
<b>Default display</b> (instantaneous current of the most heavily loaded phase)	
<b>Instantaneous and demand currents</b>	I1 I2 I3 IN Ig (Micrologic 6.0 E)  I1 I2 I3 IN 
<b>Instantaneous current maximeters</b> To reset current maximeters, see page 27.	I1 I2 I3 IN Ig (Micrologic 6.0 E) 
<b>Voltages (3-wire systems)</b>	V12 V23 V31 
<b>Voltages (4-wire systems)</b>	V1N V2N V3N V12 V23 V31 
<b>Power</b> Active Power is displayed positively or negatively according to the parameter Power sign (see page 32).	P PF Q S Demand P 
<b>Active energy</b> Ep is displayed in MWh on 2 screens, see details on page 26. To reset active energy, see page 27.	Ep (MWh) Ep (MWh) 
<b>Trip history</b> (see details on page 28)	The trip history displays the list of the last ten trips.
<b>Protection settings display</b> (see details on page 29)	The protection settings displayed depend on the model of the Micrologic E control unit.
Setting tree branches	Screens
<b>Communication settings</b> (see details on page 32)	
<b>Measurement settings</b> (see details on page 32)	
<b>Output settings (with optional M2C contacts)</b> (see details on page 32)	
<b>Software version</b>	

# Tree Navigation mode

## Micrologic E set-up

### Set-up parameters













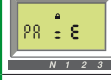

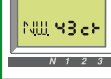
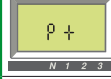
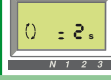

Micrologic E has three types of set-up parameters:



- communication settings
- measurement settings
- M2c output settings.

The corresponding parameters (Address, Baud rate, etc.) have default values that can or must be changed according to the needs of the installation or users.

The following table lists these parameters and indicates their possible values. The procedure to change the settings is described on the next page.

The parameters are displayed in the order indicated in the table below.

Parameters	Definition	Format (X = digit)	Default value (units)	Default screen <sup>(2)</sup>	Possible values
<b>Communication settings <sup>(1)</sup> for Micrologic E with communication option (Modbus network)</b>					
Modbus address	Address of Micrologic E on the Modbus network to which it is connected.	XX	47		1 to 47
Baud rate	Number of kbits exchanged per second (kbauds on the Modbus network).	XX.X	19.2 (kb)		4.8 9.6 19.2
Parity	Used for error checking based on the number of bits in the transmitted data group.	E or n	E		E (Even) n (None)
Modbus connection	Type of Modbus connection: 4-wire (4) or 2-wire + ULP (ULP)	4 or ULP	4		4 ULP
<b>Measurement settings</b>					
Interval (window) for demand power calculation	Period of time over which the demand power is calculated.	XX	15 (minutes)		5 to 60 (in 1 minute steps)
Interval (window) for demand current calculation	Period of time over which the demand current is calculated.	XX	15 (minutes)		5 to 60 (in 1 minute steps)
Type of network (3-wire or 4-wire) and number of circuit breaker poles (CTs).	<ul style="list-style-type: none"> <li>■ Setting 43 = 4-wire (3ph+N) and 3-pole CB (3 CTs) <sup>(3)</sup></li> <li>■ Setting 44 = 4-wire (3ph+N) and 4-pole CB (4 CTs) or 3-pole CB (3 CTs) + external CT</li> <li>■ Setting 33 = 3-wire (3ph) and 3-pole CB (3 CTs) <sup>(4)</sup></li> </ul>	XX	43		43 44 33
Power sign	By default, the Micrologic E considers power flowing into the circuit breaker via the top terminals to loads connected to the bottom terminals as positive (top fed).	+ or --	+		+ --
Quick View display duration	Duration of display of each screen in Quick View mode	()	2 (s)		1 to 9
<b>Output settings for Micrologic E with optional M2C contacts</b>					
Output	Two outputs are available via the 2 optional M2C contacts: <ul style="list-style-type: none"> <li>■ Out 1 and Out 2.</li> </ul> Setting possibilities are the same for both.				Out 1 Out 2
Event assigned to the output	Various events can be assigned to each output: <ul style="list-style-type: none"> <li>■ 3 trip events:                             <ul style="list-style-type: none"> <li><input type="checkbox"/> tripping caused by Ir</li> <li><input type="checkbox"/> tripping caused by Isd or Ii</li> <li><input type="checkbox"/> tripping caused by Ig (Micrologic 6.0 E)</li> </ul> </li> <li>■ 2 pre-alarm events:                             <ul style="list-style-type: none"> <li><input type="checkbox"/> Ir pre-alarm</li> <li><input type="checkbox"/> Ig pre-alarm (Micrologic 6.0 E)</li> </ul> </li> </ul>				Not assigned
					Ir trip
					Isd (includes Ii) trip
					Ig trip (6.0 E)
					Ir pre-alarm
					Ig pre-alarm (6.0 E)
Output state	The output state (normally "0") can be controlled in three ways: <ul style="list-style-type: none"> <li>■ forced to 1 (for testing)</li> <li>■ forced to 0 (for testing)</li> <li>■ changed from 0 to 1 (without latching) on occurrence of the assigned event (normal mode)</li> </ul>				Forced to 1
					Forced to 0
					Normal mode (no latching)

<sup>(1)</sup> When the communication option is used, the communication parameters must be set. The communication module should be set up only when installed. Modification of a parameter on a system already in operation may lead to communication faults. <sup>(2)</sup> Note that all the default screens include a closed padlock icon . This means the value is protected. You must open the padlock  to modify the settings and close the padlock after your modification in order to protect the new value. The procedure is described on the next page. <sup>(3)</sup> Important: for 3-pole circuit breakers used on 4-wire systems (3ph + N), terminal VN on the Micrologic control unit must always be connected to the neutral. If this is not done, the phase-to-neutral voltage measurements can be erroneous. <sup>(4)</sup> Important: for 3-pole circuit breakers used on 3-wire systems (neutral not distributed), always set this value to 33 (see below) to avoid indications of a meaningless phase-to-neutral voltage.

# Optional M2C contacts

## Micrologic E programmable outputs

**Important:**  
The M2C contacts require an auxiliary power supply.

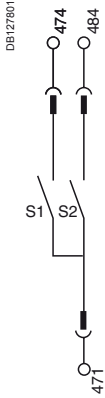

Wiring diagram for M2C contacts.

### Possible functions

The Micrologic E control unit can be equipped with up to two M2C contacts (S1 and S2) that can be used to activate:

- alarms to signal and identify tripping caused by long-time, short-time, instantaneous or ground-fault protection
- pre-alarms to warn of imminent tripping by ground-fault (Micrologic 6.0 E) or long-time protection.

### Contact operation

The contacts can be set to change the state of Micrologic E outputs Out1 and/or Out2 from 0 to 1 when certain events occur:

- trip events, i.e. when the control unit is tripped by:
  - long-time protection I<sub>r</sub>
  - short-time instantaneous protection I<sub>sd</sub> or I<sub>i</sub>
  - ground-fault protection I<sub>g</sub> (Micrologic 6.0 E only)
- pre-alarm events, i.e. when the current reaches 90 % of the following trip thresholds:
  - long-time protection setting I<sub>r</sub>
  - ground-fault protection pickup I<sub>g</sub> (Micrologic 6.0 E only).

For details on how to assign different events to the contacts, see "Output settings" on page 32 or the example on page 35.

### Latching settings

When the output state setting is in "Normal mode" (see page 32), the contacts are non-latching, i.e. the contact remains activated (state = 1) only as long as the event that caused the change of state remains present.

Two other output state settings are available (forced to 1 or 0) for testing needs (see page 32).

### Time delays

- Pickup: when the current exceeds the selected tripping or pre-alarm pickup threshold, the output state changes from 0 to 1 after a fixed time delay of 1 second.
- Dropout: when the circuit is opened by the circuit breaker or when the current falls below the pre-alarm dropout threshold (see page 17), the output state returns to 0 after a non-adjustable time delay of 1 second.

### Contact operating diagrams

Contact operating diagram for long-time, short-time, instantaneous and ground-fault protection trip alarms

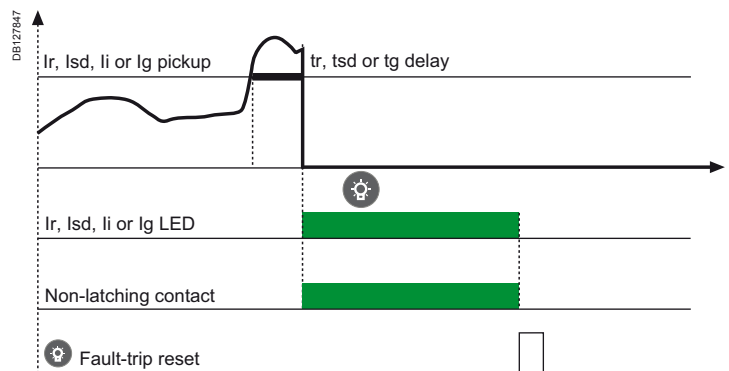

Contact operating diagram for I<sub>r</sub> and I<sub>g</sub> pre-alarms

