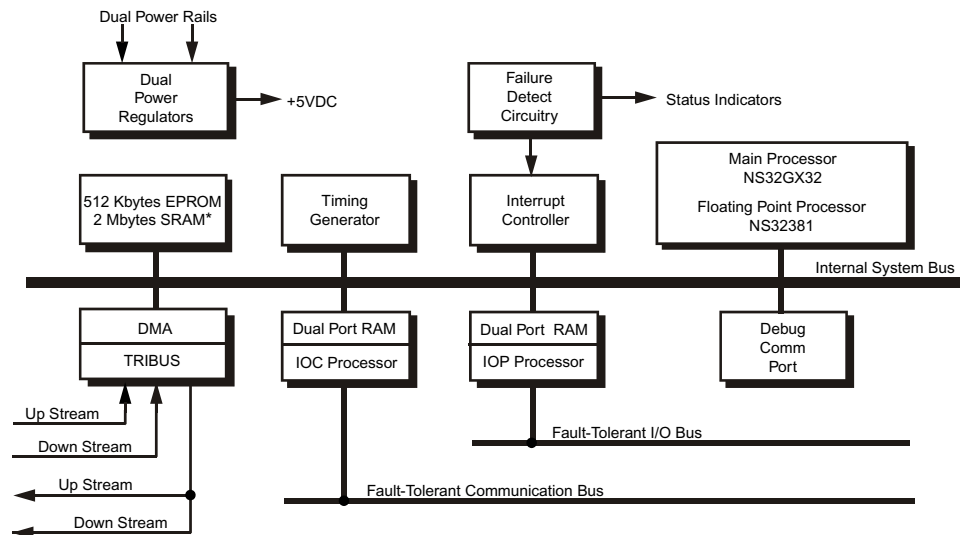

**Table 8 3008 Main Processor Specifications**

Feature	Description
Serial port	For diagread diagnostic analysis Optically isolated RS-232 interface on one 25-pin connector 500 VDC isolation
Communication processor	Motorola MPC860, 50 MHz, 32-bit
Communication interface	
Protocol	RS-485
Baud rate	2 megabits per second
I/O interface	
Protocol	RS-485
Baud Rate	375 kilobits per second
Logic power	10 W

## 3006 and 3007 Main Processor Architecture

This figure depicts the model 3006 and 3007 Main Processor architecture, which can be used with Tricon v9.0 – v9.5 systems. They have the same architecture and specifications, except for SRAM, which is 2 megabytes for the 3006 and 1 megabyte for the 3007.

**Figure 16 3006 and 3007 Main Processor Architecture**

## 3006 and 3007 Specifications

This table lists the specifications for the 3006 and 3007 Main Processors, which can be used with Tricon v9.0 – v9.5 systems.

**Table 9 3006 and 3007 Main Processor Specifications**

Feature	Specification
Central processor	National NS32GX32, 32 bits, 25 MHz
Math co-processor	National NS32381, 32 bits, 25 MHz
EPROM memory	512KB
SRAM	Model 3006: 2 MB Model 3007: 1 MB
Clock calendar	Time and date Battery backup Typical drift: $\pm 2$ seconds per day Maximum drift: $\pm 8.6$ seconds per day
TriBus	4 megabits per second, 16-bit DMA
Serial port	For Diagread diagnostic analysis Optically isolated RS-232 interface on one 25-pin connector 500 VDC isolation
Communication processor	Intel 80C152 32 KB EPROM, 64K shared memory interface 16 MHz
Communication Interface	
Protocol	RS-485
Baud rate	2 megabits per second
I/O processor	Intel 80C31 12 MHz 32 KB EPROM 64K Shared Memory Interface
I/O interface	
Protocol	RS-485
Baud Rate	375 kilobits per second
Logic power	15 W

## Diagnostics for Main Processors

Extensive diagnostics validate the health of each Main Processor as well as each I/O module and communication channel. Transient faults are recorded and masked by the hardware majority-voting circuit. Persistent faults are diagnosed, and the errant module is hot-replaced or operated in a fault-tolerant manner until hot replacement is completed.

Main Processor diagnostics include these features:

- Verify fixed-program memory
- Verify the static portion of RAM
- Test all basic processor instructions and operating modes
- Test all basic floating-point processor instructions
- Verify the shared memory interface with I/O processors
- Verify each I/O processor, communication processor, local memory, shared memory access, and loopback of RS-485 transceivers
- Verify the TriClock interface
- Verify the Tribus interface

A standard, 25-pin, male D-connector (RS-232) at the bottom of each MP operates at 9600 bits per second and can be used by Triconex representatives for diagnostic analysis. The RS-232 port is fully isolated (500 VDC, maximum) to provide protection against ground faults.