

Trusted Power Distribution Unit MCB 24 Vdc

Product Overview

The dual 5-channel Trusted® Power Distribution Unit Miniature Circuit Breaker (MCB) 24 V is designed for N+1 or 100 % redundant 24 Vdc power distribution applications. The unit is designed to be mounted on a standard DIN rail. Monitoring circuits provide local LED indication of individual MCB 'trip' status and a relay contact provides a common alarm signal output.

Features:

- Four 'dual' 24 Vdc, 20 A MCB protected outputs - suitable for direct connection to a Trusted Controller/Expander Chassis or upstream protection for the Trusted 15-way Fused Distribution Unit (T8293).
- One 'dual' 24 Vdc, 3 A MCB protected output - suitable for direct connection to Trusted Fan Trays or other low power devices.
- Visual indication of MCB status.
- Common alarm output of MCB status via a volt-free contact.
- Option link for N+1 or 100 % redundant distribution.

ISSUE RECORD

Issue	Date	Comments
7	Sep 05	Format
8	Nov 08	Clarified distribution
9	Apr 10	Option 4 change
10	Jun 16	Rebranded and updated to incorporate IEEE standards with correction of typographical errors and also standardise the Relative Humidity Range and Operating Temperature Statements in the Specification Section.

1. Description

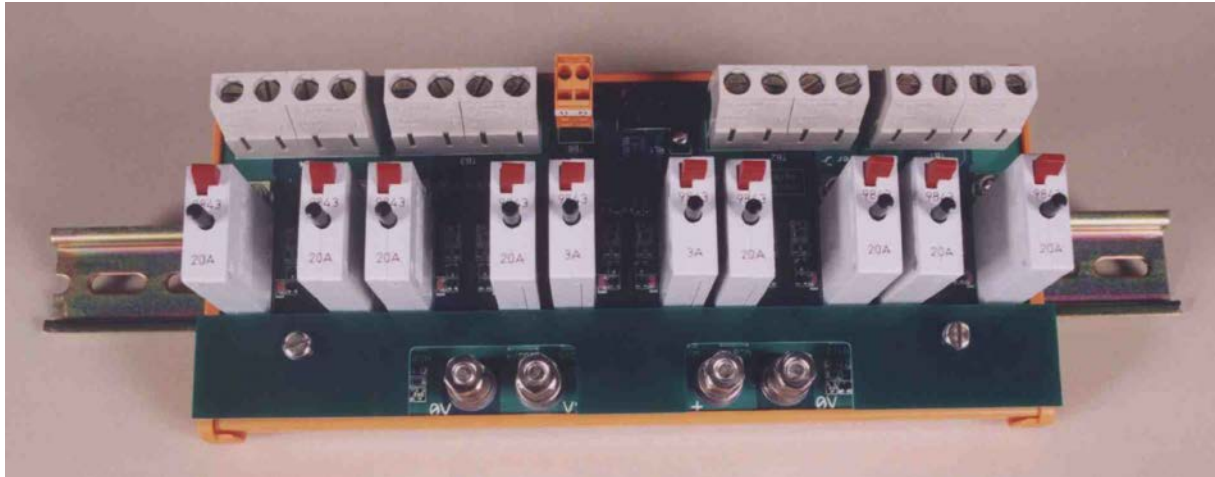

Figure 1 T8292 Photo

The schematic diagram for the Trusted Power Distribution Unit MCB 24 Vdc is shown in Figure 2 below.

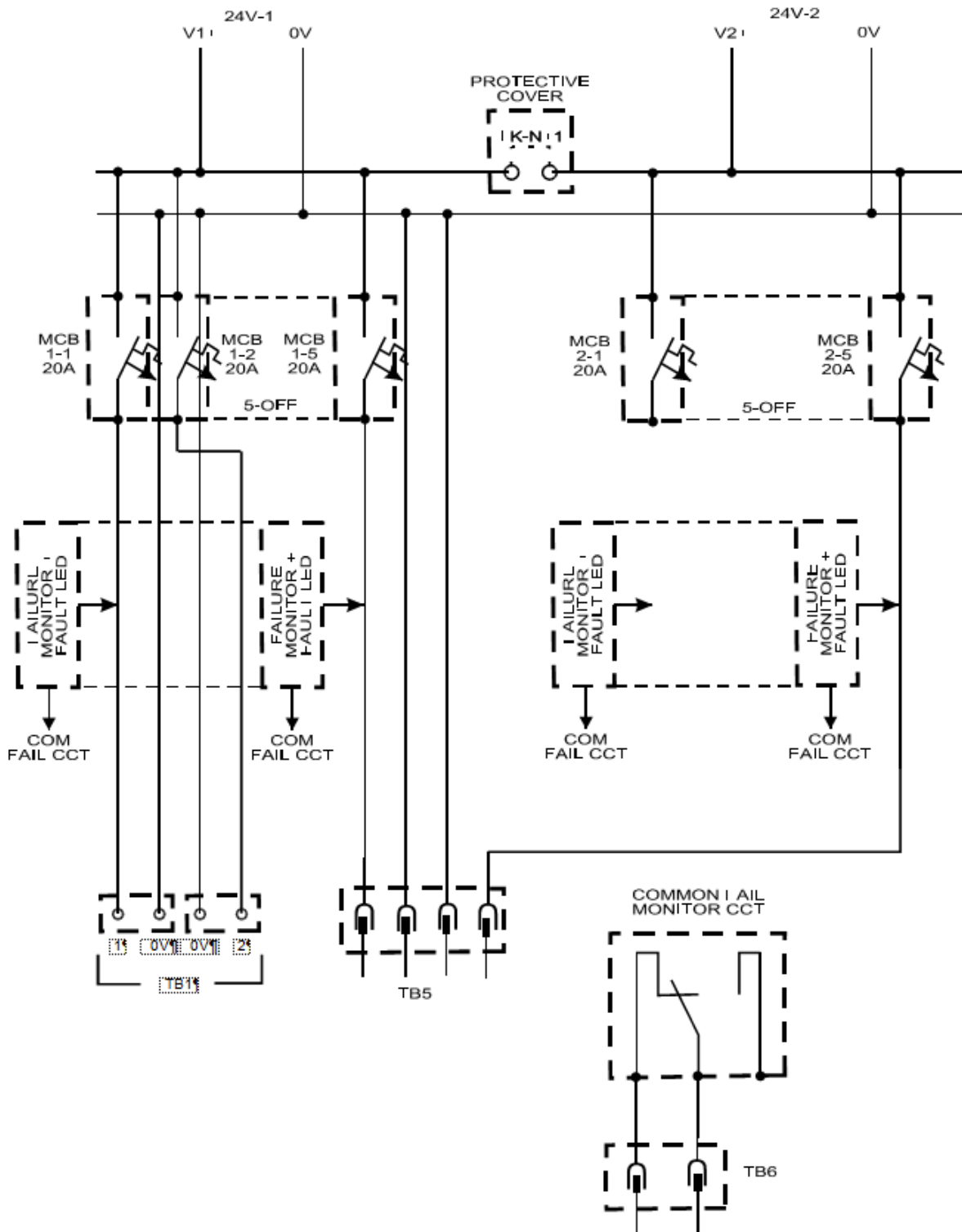

Figure 2 Trusted Power Distribution Unit MCB 24 Vdc Schematic Diagram

Only one 20 A output TB1 is shown for clarity. Note that both 24 V supplies on TB1 are connected to feeder 24V-1. TB2 is also wired to 24V-1. TB3 and TB-4 are powered from 24V-2. This means that if a separated dual redundant supply is required, each output must

be wired to one supply on 24V-1 and one supply on 24V-2. Figure 3 shows a simplified diagram of the connections.

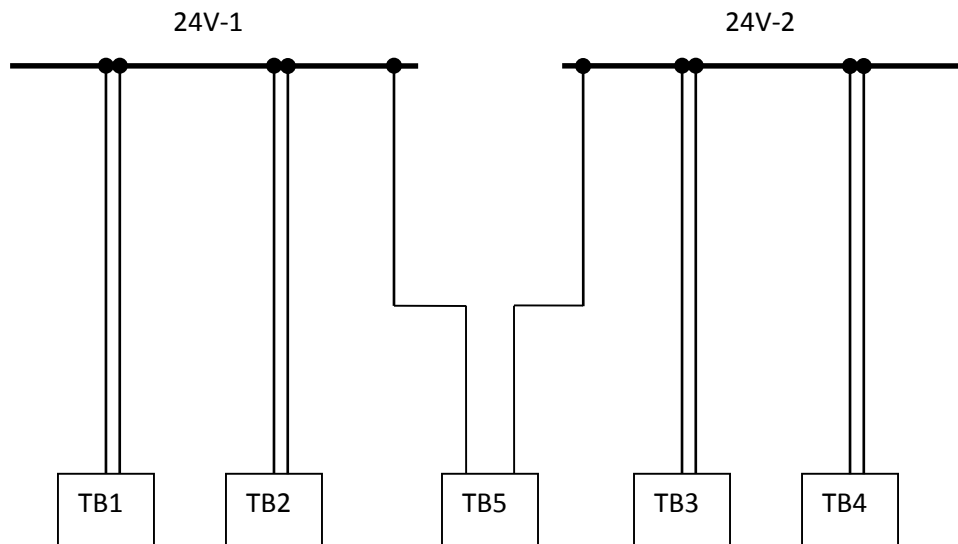

Figure 3 Single line power diagram

Power fed to the Trusted Power Distribution Unit MCB 24 V is sub-distributed via the dual MCBs either as an N+1 or 100 % redundant configuration, via the fitting (for N+1) or removal of the board mounted link, LK-N+1.

The standard factory-fitted configuration is N+1.

Each MCB is monitored for open circuit condition and provides a local on-board LED indication of individual 'trip' status (red LED displayed for tripped).

A volt-free relay contact provides the common alarm output signal (contact open for tripped) for connection to external alarm monitoring circuits.

For modules up to issue 5 the maximum difference between supply feeds must not exceed 1 V.

6. Terminal Connections

The terminal connections for the Trusted Power Distribution Unit MCB 24 V are shown below.

Terminal	Description
0V1	0 V - Incoming Supply 1
V1+	24 Vdc - Incoming Supply 1
0V2	0 V - Incoming Supply 2
V2+	24 Vdc - Incoming Supply 2
TB1-1	24 Vdc from MCB 1-1
TB1-2	24 Vdc from MCB 1-2
TB1-0V (2-off)	0 V associated with MCBs 1-1 and 1-2
TB2-3	24 Vdc from MCB 1-3
TB2-4	24 Vdc from MCB 1-4
TB2-0V (2-off)	0 V associated with MCBs 1-3 and 1-4
TB3-5	24 Vdc from MCB 2-4
TB3-6	24 Vdc from MCB 2-3
TB3-0V (2-off)	0 V associated with MCBs 2-4 and 2-3
TB4-7	24 Vdc from MCB 2-2
TB4-8	24 Vdc from MCB 2-1
TB4-0V (2-off)	0 V associated with MCBs 2-2 and 2-1
TB5-1	24 Vdc from MCB 1-5
TB5-2	0 V associated with MCB 1-5
TB5-3	0 V associated with MCB 2-5
TB5-4	24 Vdc from MCB 2-5

Table 2 Terminal Connections

7. Specifications

Voltage Range	22 Vdc to 28 Vdc
Input Current	60 A max
MCB Outputs	4-off, 2x24 V and 2x0 V at 20 A 1-off, 1x24 V and 1x0 V at 3 A
Common Alarm Output	1-off N/O volt-free contact - closed in the healthy state
Connectors	LU10.16 screw clamp terminal FCI Qikmate SMS series connector
Conductor Clamping Range (LU10.16)	0.5 mm ² to 16 mm ²
Max Switching Voltage	60 Vdc or 125 Vac
Operating Temperature	0 °C to +60 °C (+32 °F to +140 °F)
Non-operating Temperature	-25 °C to +70 °C (-13 °F to +158 °F)
Relative Humidity range (operating, storage and transport)	10 % – 95 %, non-condensing
Environmental Specifications	Refer to Document 552517
Dimensions	
Height	108 mm (4.2 in)
Width	240 mm (9.4 in)
Depth	109 mm (4.3 in)
Weight	823 g (1.8 lb)