

Trusted 40 Channel Analogue Input FTA

Product Overview

The Trusted® 40 Channel Analogue Input Field Termination Assembly (FTA) T8830 is designed to act as the main interface between a field device generating an analogue signal and the Trusted TMR Analogue Input Module T8431.

Features:

- 40 input channels per FTA.
- Industry standard field device connections (2-wire).
- Standard DIN rail compatibility.
- Simple installation and connection.
- 24 Vdc operation.
- SmartSlot connection for 'one to many' hot replacement of input modules.
- Fused field power supply per channel.
- On-board Light Emitting Diode (LED) indication of field power supply integrity.

1. Description

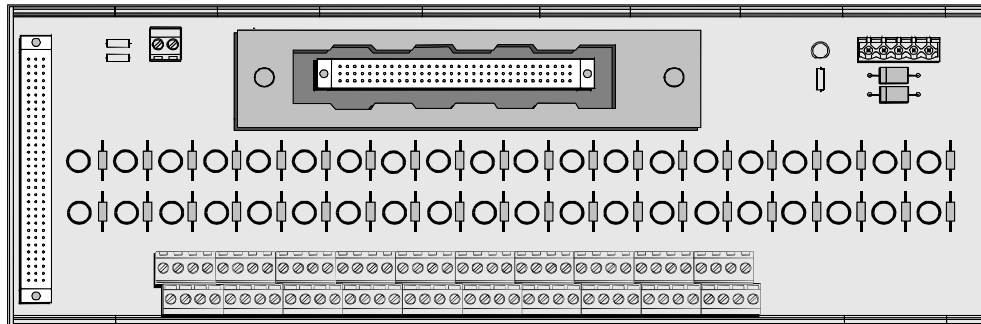

Figure 1 T8830 Layout

The Trusted 40 Channel Analogue Input FTA T8830 provides termination for a maximum of 40 input channels from various types of field devices which generate an analogue input. Figure 2 below shows the configuration of a single channel.

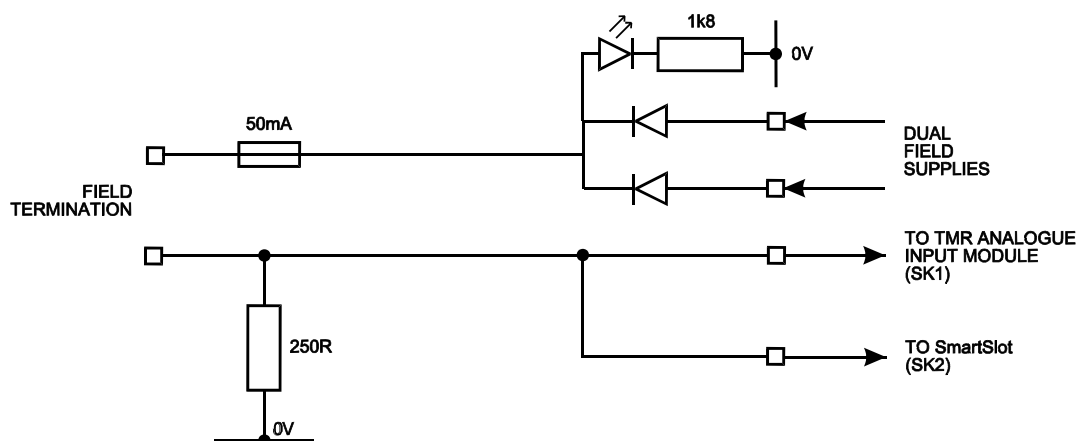

Figure 2 Single Channel Schematic

The supply for the field is derived from dual 24 Vdc feeds which are 'commoned' via diodes on the FTA. Indication of the presence of the power supply is provided by a green LED. The supply is then fed to each channel.

The supply voltage to the field is fed via the 50 mA fuse. This effectively limits the current in the field loop. The voltage developed across the 250 Ω resistor due to the incoming analogue signal from the field device is fed directly to the analogue input module.

The cable linking the 40 channels on the input module to the FTA is terminated at the 96-way socket SK1. SmartSlot (Version 1) signals from the module are connected to SK1. The SmartSlot connector is SK2 and is also a 96-way socket. This connector is not used where SmartSlot Version 2 is employed within the Trusted System. The dual dc field power supplies are connected to the FTA via a 5-way terminal block PWR TB. The input signals from the

field (40-off) are connected by 2-wire arrangements terminated on 12-off 3-way terminal blocks and 2-off 2-way.

2. Installation

Trusted 40 Channel Analogue Input FTA T8830 is designed to be mounted on either of the TS32 or TS35 DIN rails in the horizontal or vertical positions as required.

3. Associated Cable Selection

Refer to the product descriptions detailed below:

PD-TC000	Trusted Power Cables
PD-TC200	Trusted I/O Companion Slot Cables
PD-TC500	Trusted I/O SmartSlot Cables

4. Assembly Pinout Connections

4.1. PWR TB Connections

Pin	Service
1	24 V-A
2	24 V-B
3	0 V
4	0 V
5	24 V (auxiliary supply for use when required)

Table 1 PWR TB Connections

4.2. TB3 (Auxiliary Input)

Pin	Service
1	Chan 0 (not configured)
2	Chan 41(not configured)

Table 2 TB3 (Auxiliary Input) Connections

4.3. TB2 (Field Terminals)

Pin	Service	Pin	Service
1	Chan 1 24 Vdc field supply	2	Chan 1 signal from field
3	Chan 2 24 Vdc field supply	4	Chan 2 signal from field
5	Chan 3 24 Vdc field supply	6	Chan 3 signal from field
7	Chan 4 24 Vdc field supply	8	Chan 4 signal from field
9	Chan 5 24 Vdc field supply	10	Chan 5 signal from field

Pin	Service	Pin	Service
11	Chan 6 24 Vdc field supply	12	Chan 6 signal from field
13	Chan 7 24 Vdc field supply	14	Chan 7 signal from field
15	Chan 8 24 Vdc field supply	16	Chan 8 signal from field
17	Chan 9 24 Vdc field supply	18	Chan 9 signal from field
19	Chan 10 24 Vdc field supply	20	Chan 10 signal from field
21	Chan 11 24 Vdc field supply	22	Chan 11 signal from field
23	Chan 12 24 Vdc field supply	24	Chan 12 signal from field
25	Chan 13 24 Vdc field supply	26	Chan 13 signal from field
27	Chan 14 24 Vdc field supply	28	Chan 14 signal from field
29	Chan 15 24 Vdc field supply	30	Chan 15 signal from field
31	Chan 16 24 Vdc field supply	32	Chan 16 signal from field
33	Chan 17 24 Vdc field supply	34	Chan 17 signal from field
35	Chan 18 24 Vdc field supply	36	Chan 18 signal from field
37	Chan 19 24 Vdc field supply	38	Chan 19 signal from field
39	Chan 20 24 Vdc field supply	40	Chan 20 signal from field
41	Chan 21 24 Vdc field supply	42	Chan 21 signal from field
43	Chan 22 24 Vdc field supply	44	Chan 22 signal from field
45	Chan 23 24 Vdc field supply	46	Chan 23 signal from field
47	Chan 24 24 Vdc field supply	48	Chan 24 signal from field
49	Chan 25 24 Vdc field supply	50	Chan 25 signal from field
51	Chan 26 24 Vdc field supply	52	Chan 26 signal from field
53	Chan 27 24 Vdc field supply	54	Chan 27 signal from field
55	Chan 28 24 Vdc field supply	56	Chan 28 signal from field
57	Chan 29 24 Vdc field supply	58	Chan 29 signal from field

Pin	Service	Pin	Service
59	Chan 30 24 Vdc field supply	60	Chan 30 signal from field
61	Chan 31 24 Vdc field supply	62	Chan 31 signal from field
63	Chan 32 24 Vdc field supply	64	Chan 32 signal from field
65	Chan 33 24 Vdc field supply	66	Chan 33 signal from field
67	Chan 34 24 Vdc field supply	68	Chan 34 signal from field
69	Chan 35 24 Vdc field supply	70	Chan 35 signal from field
71	Chan 36 24 Vdc field supply	72	Chan 36 signal from field
73	Chan 37 24 Vdc field supply	74	Chan 37 signal from field
75	Chan 38 24 Vdc field supply	76	Chan 38 signal from field
77	Chan 39 24 Vdc field supply	78	Chan 39 signal from field
79	Chan 40 24 Vdc field supply	80	Chan 40 signal from field

Table 3 TB2 (Field Terminals) Connections

4.4. SK1 and SK2

	C	B	A
1	SmartSlot Link C	SmartSlot Link B	SmartSlot Link A
2			
3	Chan 28 (+)	Chan 14 (+)	Chan 0 (+)
4	Chan 28 (+)	Chan 14 (+)	Chan 0 (+)
5	Chan 29 (+)	Chan 15 (+)	Chan 1 (+)
6	Chan 29 (+)	Chan 15 (+)	Chan 1 (+)
7	Chan 30 (+)	Chan 16 (+)	Chan 2 (+)
8	Chan 30(+)	Chan 16 (+)	Chan 2 (+)
9	0 V	0 V	0 V
10	Chan 31 (+)	Chan 17 (+)	Chan 3 (+)

	C	B	A
11	Chan 31 (+)	Chan 17 (+)	Chan 3 (+)
12	Chan 32 (+)	Chan 18 (+)	Chan 4 (+)
13	Chan 32 (+)	Chan 18 (+)	Chan 4 (+)
14	Chan 33 (+)	Chan 19 (+)	Chan 5 (+)
15	Chan 33 (+)	Chan 19 (+)	Chan 5 (+)
16	Chan 34 (+)	Chan 20 (+)	Chan 6 (+)
17	Chan 34 (+)	Chan 20 (+)	Chan 6 (+)
18	Chan 35 (+)	Chan 21 (+)	Chan 7 (+)
19	Chan35 (+)	Chan 21 (+)	Chan 7 (+)
20	0 V	0 V	0 V
21	Chan 36 (+)	Chan 22 (+)	Chan 8 (+)
22	Chan 36 (+)	Chan 22 (+)	Chan 8 (+)
23	Chan 37 (+)	Chan 23 (+)	Chan 9 (+)
24	Chan 37 (+)	Chan 23 (+)	Chan 9 (+)
25	Chan 38 (+)	Chan 24 (+)	Chan 10 (+)
26	Chan 38 (+)	Chan 24 (+)	Chan 10 (+)
27	Chan 39 (+)	Chan 25 (+)	Chan 11 (+)
28	Chan 39 (+)	Chan 25 (+)	Chan 11 (+)
29	Chan 40 (+)	Chan 26 (+)	Chan 12 (+)
30	Chan 40 (+)	Chan 26 (+)	Chan 12 (+)
31	Chan 41 (+)	Chan 27 (+)	Chan 13 (+)
32	Chan 41 (+)	Chan 27 (+)	Chan 13 (+)

Table 4 SK1 and SK2 Connections

5. Specifications

Voltage Range	18 Vdc to 32 Vdc
Maximum Current (Field Supply)	50 mA (fused) per loop
Power Consumption (Field Supply)	0.25 W (LED power indicator)
Operating Temperature	0 °C to +60 °C (+32 °F to +140 °F)
Non-operating Temperature	-25 °C to +70 °C (-13 °F to +158 °F)
Relative Humidity range (operating, storage and transport)	10 % – 95 %, non-condensing
Environmental Specifications	Refer to Document 552517
Dimensions	
Height	111 mm (4.4 in)
Width	335 mm (13.2 in)
Depth	51 mm (2 in)
Weight	900 g (2 lb)