

# Trusted Speed Monitor Input FTA (SIFTA)

## Product Overview

The Trusted® Speed Monitor Input Field Termination Assembly (SIFTA) is a DIN rail assembly. It provides the input field interface for three rotating machine groups when used as part of a Trusted T8442 Triple Modular Redundant (TMR) Speed Monitor system.

## Features:

- Provides all necessary input interfaces for a Trusted T8442 TMR Speed Monitor.
- Nine speed input channels arranged as three groups of three inputs.
- Separate field power inputs for each of the three speed input groups.
- Field power and signal isolation between input groups.
- Versatile input connectivity allows interfacing with:
  - Active speed sensors with totem-pole outputs.
  - Active speed sensors with open-collector outputs.
  - Passive magnetic, inductive speed sensors.
- Standard DIN Rail mounting.
- All fuses can be replaced in situ.

# 1. Product Range

Catalogue No.	Product name	Description
T8442	TMR Speed Monitor.	Trusted TMR Speed Monitor Module.
T8846	Speed Input FTA (SIFTA)	Input field termination assembly for use with the T8442 TMR Speed Monitor.
T8891	Speed Output FTA (SOFTA)	Output field termination assembly for use with the T8442 TMR Speed Monitor.
TC-801	I/O Companion Slot, Speed Monitor to FTA (Internal )	Companion Slot Input/Output (I/O) cable with internal power. This connects an active/standby hot swap pair of T8442 modules to a single SIFTA and up to three SOFTAs.

**Table 1 T8442 TMR Speed Monitor Product Range**

## 2. Assembly



**Figure 1 T8846 Module Photo**

The T8846 Speed Input Field Termination Assembly (SIFTA) is an integral part of the overall T8442 Speed monitor system. It is DIN rail mounted, containing passive signal conditioning, power distribution and protection components.

Each T8442 Speed Monitor Module hot swap pair requires a single T8846 SIFTA when installed in a Trusted system.

The SIFTA has nine identical speed transducer signal conditioning circuits arranged as three groups of three.

Each of the three groups is a galvanically isolated entity, with its own field power and I/O signal interfaces.

Multiple sensors must be employed for SIL 3 applications.

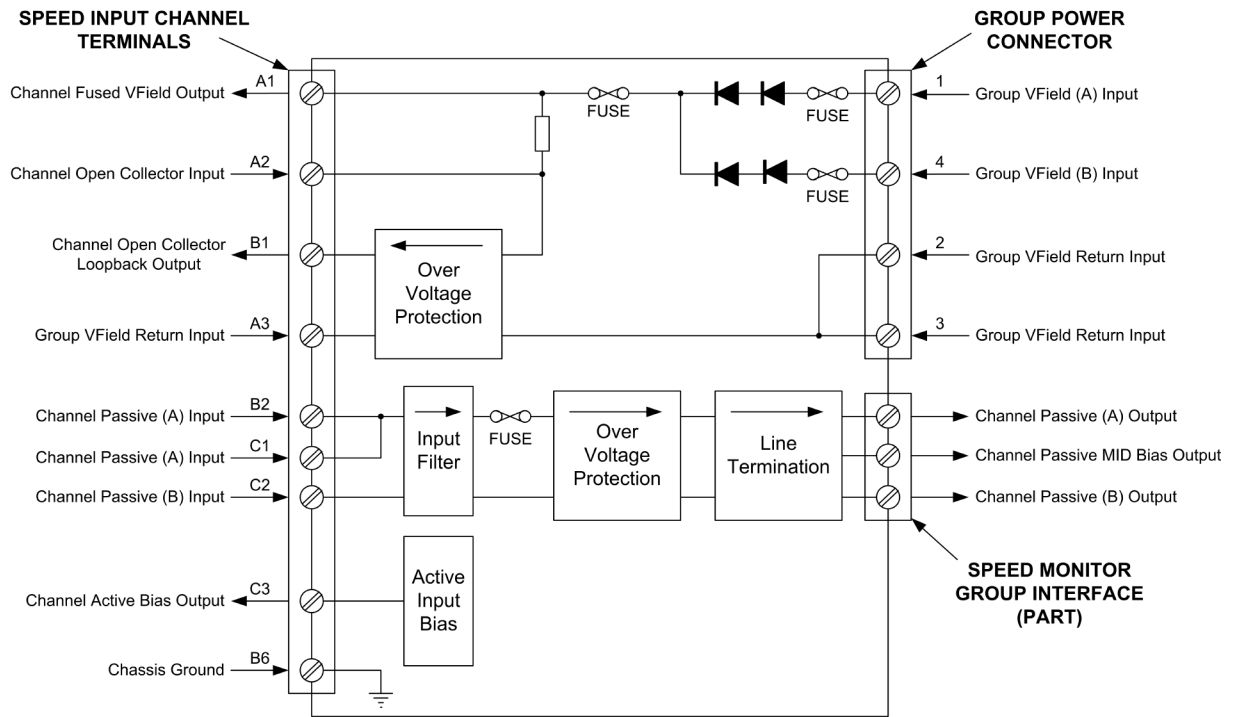

Figure 2 T8846 Speed Input Channel Overview

### 3. External Interfaces

Figure 3 shows the T8846 general assembly.

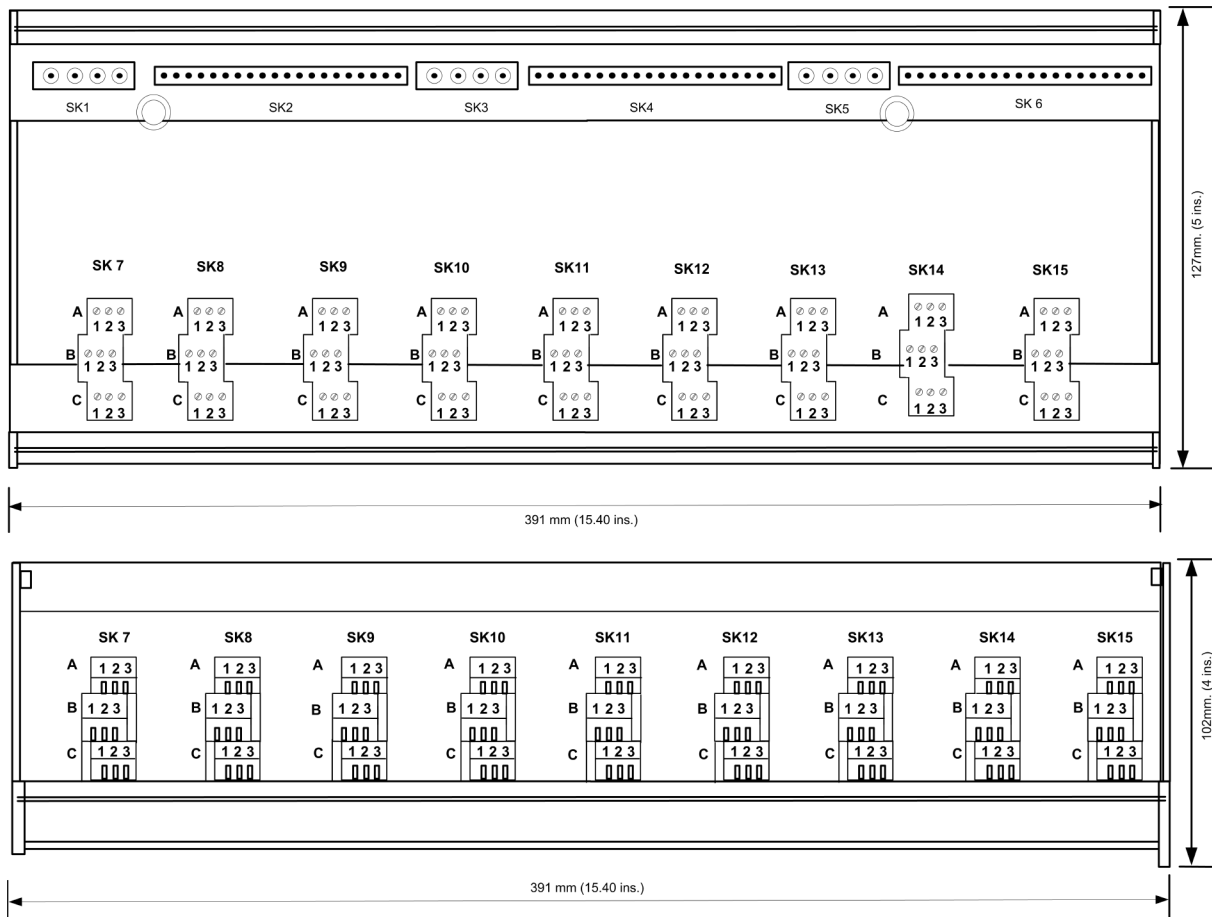

Figure 3 T8846 General Assembly – Top View and Front View

#### 3.1. Field Power Inputs

This section details the field power input connections for each speed monitor input group.

There are three 4-way connectors on the FTA which provide the field power interface to the FTA. Each connector is dedicated to one speed input group.

## 5. Specifications

### 5.1. Group Vfield Power Supply Input Specifications

Parameter	Min	Type	Max	Unit	Notes
Group Vfield Input Voltage Range Vfield (A) and Vfield (B) Inputs	18		32	Vdc	With respect to Group Vfield Return
Maximum Group Vfield Input Current Vfield (A) and Vfield (B) Inputs			1	A	

Table 7 Group Vfield Power Supply Input Specifications

### 5.2. Group Speed Input Specifications

Parameter	Min	Type	Max	Unit	Notes
<b>Group Vfield Output</b>					
Group Vfield output voltage @ 50 mA load current		22.6		Vdc	Vfield input voltages @ 24 Vdc
Maximum Group Vfield output current		62.5		mA	
<b>Group Speed Inputs</b>					
Open Collector Input Pull-up resistance to Group Vfield		2000		$\Omega$	
Maximum Open Collector Input Voltage			33	V	With respect to Group Vfield Return
Open collector Input to Open collector output resistance		4990		$\Omega$	
Active Input Bias Voltage output with respect to Group Vfield Return		1.90		Vdc	Group Vfield Input = 24 Vdc
Differential input resistance Passive (A) and Passive (B) Inputs		632		$\Omega$	

Parameter	Min	Type	Max	Unit	Notes
Maximum Differential Input Voltage Passive (A) and Passive (B) Inputs			10	V	632 $\Omega$ input resistance

Table 8 Group Speed Input Specifications

### 5.3. General Specifications

Parameter	Min	Type	Max	Unit	Notes
<b>Temperature</b>					
Operating temperature	0		+60	°C	
Storage temperature	-25		+70	°C	
Temperature change			$\pm 0.5$	°C/min	
Relative Humidity range (operating, storage & transport)	10		95	%	Non-Condensing
<b>Dimensions</b>					
Height		102 (4.0)		mm (in)	Refer to Figure 3
Width		391 (15.40)		mm (in)	
Depth		127 (5.0)		mm (in)	
Weight		0.75 (1.6)		kg (lb)	

Table 9 General Specifications

### 5.4. Isolation Specification

Isolation	Level
Between Speed Groups 1, 2 & 3	50 V Reinforced (continuous) <sup>(1)</sup> 250 V Basic (fault) <sup>(2)</sup> [Type tested at 2436 Vdc for 60 s].
Between Chassis Ground and Speed Groups 1, 2 & 3	

Note 1) 50 Vrms Secondary circuit derived from Mains, OVC II up to 300V.

Note 2) 250 Vrms Mains circuit, OVC II up to 300V. Exposure to voltages at these levels shall be temporally constrained consistent with the system MTTR.