

7.2 QPP-0002

7.2.1 Quad Processor Pack

The Quad Processor Pack (QPP-0002) is the second generation (enhanced performance) processing module of Safety Manager and is located in the Controller chassis (see section CPCHAS-0001 or CPCHAS-0002 or CPCHAS-0003).

The QPP-0002 is backwards compatible with, and a one-on-one spare part for the QPP-0001, when installed in Safety Managers running R121 firmware or higher.

Attention:

You can only remove or replace the QPP-0002 module safely when the key switch is in *STOP!*

A non-redundant Controller contains one QPP-0002 module, a redundant Controller contains two QPP-0002 modules.

The slot of the Quad Processor Packs within the Controller chassis is pre-determined (see Location of Control Processor modules).

The Quad Processor Pack (QPP-0002) is the heart of Safety Manager. It controls all system operations. The QPP-0002 module reads the IO input signals and executes the Controller File as created by the user in graphical Functional Logic Diagrams (FLDs). The results of the Controller File are then transmitted to the output interfaces. In Safety Manager configurations with a redundant Controller, the two QPP-0002 modules synchronize their operation through a dedicated redundant communication link between the two Control Processors. Continuous testing of the Safety Manager hardware by the QPP-0002 module ensures safe control of the process as well as extensive system and process equipment diagnostics.

The QPP-0002 module has two processors and two memory sets. Hardware data-comparators compare every read and write action of the processors, and trip the watchdog if any difference in the data is detected. Additional test hardware enables full testing of the QPP-0002 module to achieve diagnostic coverage higher than 99%. This allows one QPP-0002 module to run applications up to and including SIL3 without time limitation. Redundant Controller configurations result in a 2oo4D voting architecture.

7 Control Processor modules

7.2 QPP-0002

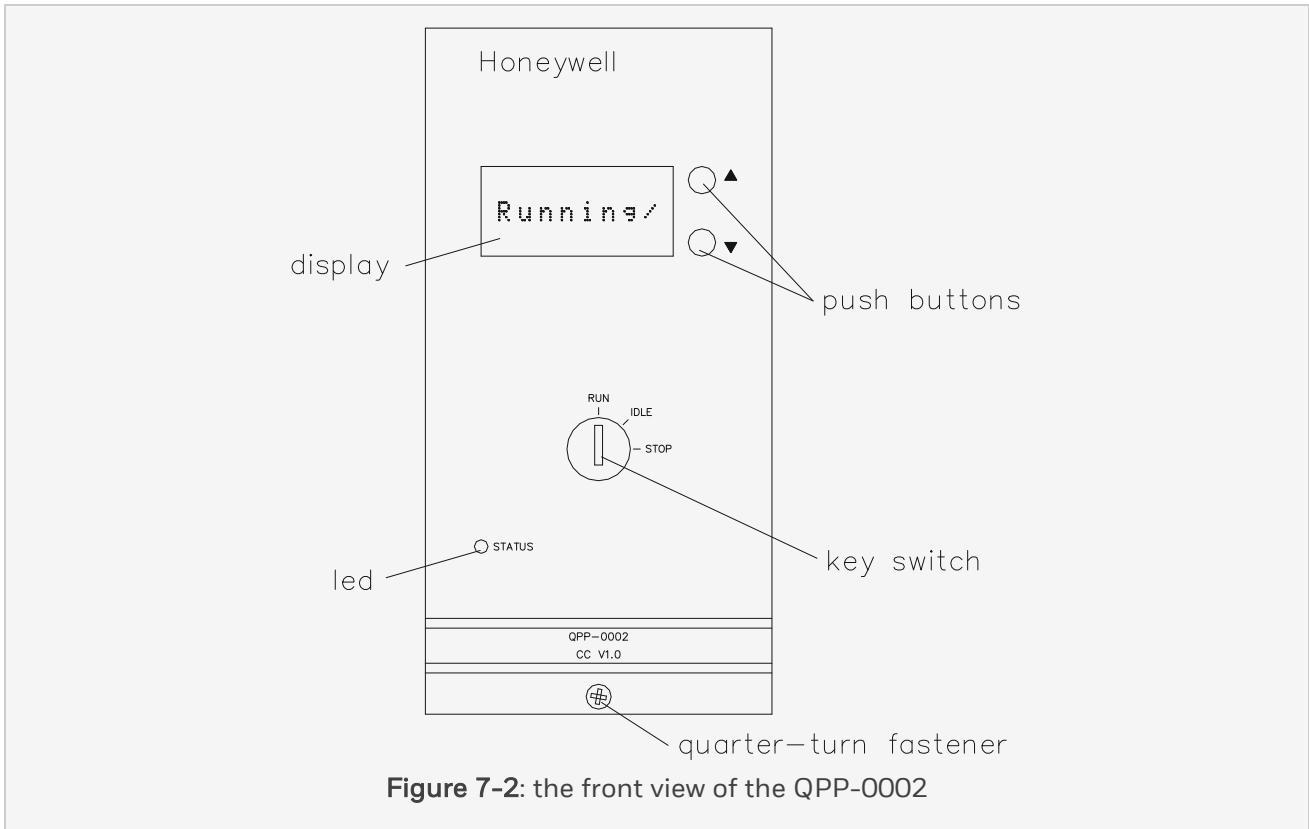

Figure 7-2: the front view of the QPP-0002

The QPP-0002 has the following components:

- Two processors running synchronously
- Flash memory for system and application program
- Flash memory for backup of system and application program
- RAM with battery backup (battery located in BKM-0001)
- A redundant communication link with the other Control Processor
- RAM for the redundant communication link data
- Data comparators for the processors and their memory
- Data exchange with its communication modules
- Watchdog (fully testable) with:

- Minimum and maximum execution time monitor
- Memory error handler
- 1oo2D functionality
- 24V and 5V monitoring
- Emergency Shut Down Input (24V)
- Two outputs (for non-redundant resp. redundant IO)
- Four IObus drivers
- Diagnostics display
- Temperature monitors
- Real time clock

7.2.2 Processors

The QPP-0002 module has two processors running synchronously during process control. During an (application-) download they may get out of sync, but after the download they will re-synchronize.

The processors run the system program (including extensive self tests and diagnostic routines) and the application program.

7.2.3 Memory

The QPP-0002 module has the following on-board memory:

- 2 × 2 Mbyte flash for the system and application program.
- 2 × 256 kbyte SRAM with battery backup (for IO, markers, counters, timers and registers).
- 2 × 512 kilobyte SRAM for data-exchange with the other Control Processor.
- 1 × 16 Mbyte flash for backup of system and application program.

The flash contents can be updated without removing the QPP-0002 from the Controller chassis.

7 Control Processor modules

7.2 QPP-0002

7.2.4 User interface

The QPP-0002 module has the following features for indicating the Controller status and allowing the user to start, stop, reset, power-up and power-down the Control Processor:

- User Interface Display
- Processor Status Key Switch
- Status LED

7.2.5 User interface display

Note:

The information on the user display may vary depending on the software version installed in the QPP.

The QPP module has a user interface display that informs the user of the status of the Control Processor and all the IO related to it.

The eight-digit display shows one message at a time, and the user can scroll between messages with the use of the buttons on the right-hand side of the display (see the below figure).

Many messages, like diagnostic messages, are divided into sub-messages, called stages (see the below table). The user interface display automatically scrolls through these stages within the current message.

When left alone for 30 seconds, the user interface display returns to the default status message.

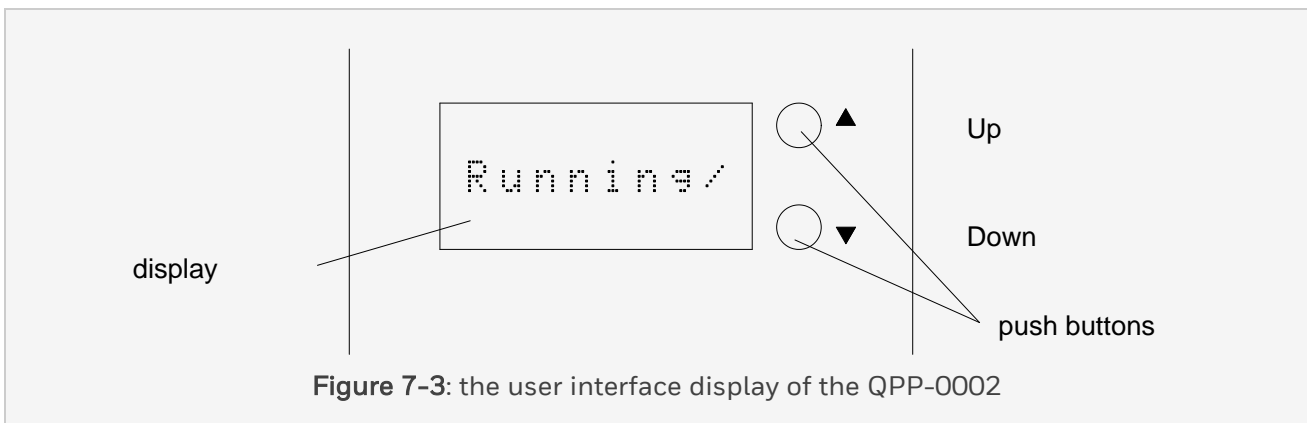

Figure 7-3: the user interface display of the QPP-0002

Messages displayed by the User Interface Display of the QPP module

Scroll	Message	Description
↑ Up Down ↓	Fail	Shows the number of diagnostic messages (N)
	Frc	Shows the number of forced points
	IP 2B	Shows the details for the selected COM port.
	IP 2A	If a COM port is configured the display shows: IP address (in two steps); Gateway; Gateway IP address (in two steps).
	IP 1B	
	IP 1A	
	Sys	Shows the Controller node number
	Vb	Shows the battery voltage for this Control Processor in Volts
	Vcc	Shows the 5VDC PSU output voltage for this Control Processor in Volts
	Tmp	Shows the temperature for this Control Processor
	Date	Shows the actual date
	Time	Shows the actual time
	R #version no.#	Shows the software version number
Default status message ¹	For details see Table 2.	
↑ Up Down	Diagnostic message N	Shows the diagnostic messages that apply for this Controller. If there are no messages the display shows “Fail 0”.

7 Control Processor modules

7.2 QPP-0002

Scroll	Message		Description
↓	↓	1. Chass 2. Slot 3. Module ID 4. Message 1 5. Message 2 6. sError #	If there are multiple messages the last 32 messages are displayed in chronological order. The last message is shown first. Select a message with the scroll buttons. When releasing a scroll button on a diagnostic message the display scrolls: <ul style="list-style-type: none"> • the fault location in two steps (chassis and slot), • the faulty module in the next step (module ID) • the message body in two steps (Message 1 & 2) • the error code in the next step (Error #) After completing this cycle the display returns to the default status message.
		Diagnostic message N-1	
	↓	1. Chass 2. Slot 3. Module ID 4. Message 1 5. Message 2 6. Error #	
1. When selecting another display message with the scroll buttons, the display will always return to this message after a time-out.			

Table 2. Possible default status messages

Status	Message ¹	Alternating with
Busy with power-on checks	<i>PowerUp</i>	
Busy synchronizing	<i>Sync</i>	
Busy loading	<i>Loading</i>	
Waiting for download to start	<i>Waiting</i>	
Waiting for download to start	<i>Waiting</i>	with Flt
Key in <i>IDLE</i> : CP halted	<i>Halt</i>	
Key in <i>RUN</i> : CP halted due to faults	<i>Halt</i>	with Flt
Key in <i>RUN</i> : CP ready to start	<i>CPReady</i>	
Running with faults	<i>Running</i>	with Flt
Running no faults	<i>Running</i>	
Loading other CP, or loading own USI	<i>Sending</i>	

1. A continuously rotating bar or a flashing star on the display indicates that the QPP is operational.

7.2.6 Processor status key switch

The QPP-0002 module contains a processor status key switch that enables the user to change the Control Processor status. This key is different from the keys of the key switches on the BKM-0001 module.

The below table shows the possible statuses of the Processor Status Key Switch.

7 Control Processor modules

7.2 QPP-0002

Table 1. Positions of the processor status key switch

Processor status key	Description
RUN	The Control Processor executes (or is ready to execute) the Application File.
IDLE	<p>The execution of the application program is ended by the processors.</p> <p>The current application and memory contents are not affected by the IDLE state.</p> <p>The Control Processor is available for loading software.</p> <p>The watchdog outputs are de-activated by the processor.</p>
STOP	<p>The Control Processor is in Hardware Reset. It is not executing any program.</p> <p>The watchdog outputs are de-activated.</p> <p>The IObus drivers are de-energized.</p>

7.2.7 Status LED

The QPP-0002 has one STATUS LED on the front side of the module.

The below table shows the possible states of this STATUS LED.

Table 1. LED indicators of the QPP-0002 module

LED	Status	Description
STATUS	Off	The power to the module is down or the Processor Status Key Switch is set to STOP.
	Red	One or more hardware errors detected on the module.
	Green	No hardware errors detected on the module.

7.2.8 SD input

The QPP-0002 has a (24 V DC) emergency Shut Down input.

A low level on the emergency Shut Down input will de-energize the watchdog outputs independently from the processor. The SD input is available on the Controller backplane and requires a normally closed (field-)contact.

The SD input is common for both Control Processors. The +24 V_SD-output is supplied by both QPP-0002 modules, but the input stays operational even if one of the QPP-0002 modules has no 24 V DC supply, or is removed.

- If the SD function is used you should connect an external potential free SD contact via the SICP-0002/L3 (see SICP-0002/L3).
- If the SD function is not used an SD link is required (default placed on the CP backplane).

This SD input is 24 V DC and galvanically isolated from the internal 5 V DC (see the below figure).

Note:

The resistor R on the 24 V input circuit of the SD input in the below figure limits the short-circuit current (to 0 V) of the +24 V_sd signal.

The external potential free SD switch is connected via a SICP-0002/L3 cable. For more details see SICP-0002/L3 and CPCHAS-0001 or CPCHAS-0003.

7 Control Processor modules

7.2 QPP-0002

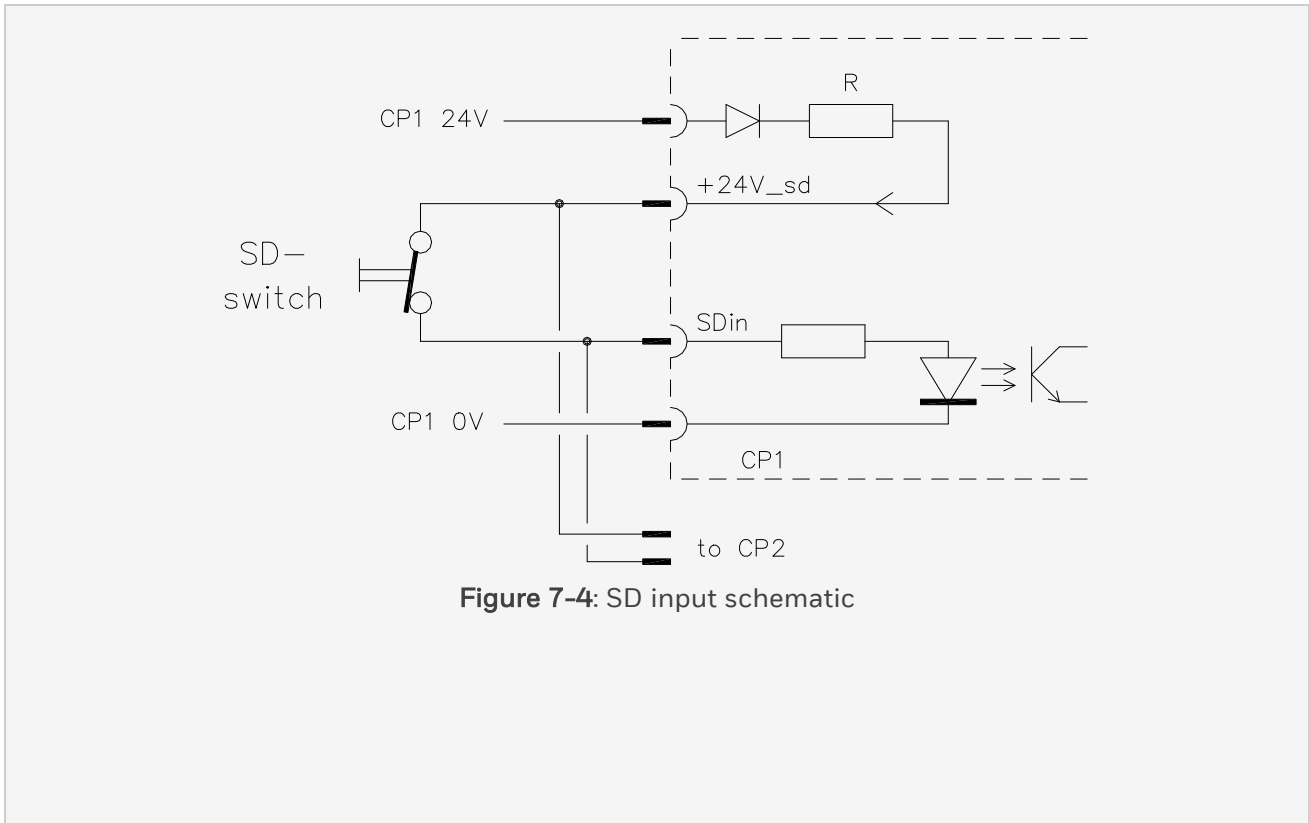

Figure 7-4: SD input schematic

7.2.9 Watchdog functionality

The Watchdog function in the QPP-0002 monitors the operation and the operating condition of the processors. The processor operation is monitored by verifying whether the processors execute all the tasks within a pre-calculated time frame, which depends on the configuration. The monitored operating conditions include the data integrity of the processor memory, the (5 V) processor supply voltage and the (24 V) IO supply voltage (both undervoltage and overvoltage). If the Watchdog detects a fault in the operation of the QPP-0002 or its operating conditions, it will deactivate its outputs and thus deactivates the safety-critical outputs of Safety Manager, independent of the QPP-0002 status.

The watchdog module monitors system parameters including:

- The application loop maximum execution time. This in order to detect if the process is executing its program correctly and is not looping (hang-up).
- The application loop minimum execution time. This in order to detect if the processor is executing its program correctly and is not skipping program parts.

- Data (-bus) differences. This will detect memory errors and processor defects.
- 5 V DC level. Overvoltage and undervoltage detection (5 V DC \pm 5%).
- 24 V DC level. Overvoltage and undervoltage detection (24 V DC -20%, +35%).
- SD input signal level.

The watchdog also includes the following features:

- A 1oo2D functionality.

The processor has the capability to de-energize the watchdog of the other (redundant) processor in the Controller chassis.

- A (second) watchdog-output for the non-redundant IO modules. This output is connected in parallel with the (second) output of the other processor in the Controller chassis. The output is used to energize the watchdog input of non-redundant IO chassis and will stay 'high' as long as at least one of the processors keeps its (second) output high. If a fault is detected in a module in the non-redundant IO section, the processors can switch off this 'second' watchdog-output and keep the redundant IO modules online.

In order to be able to test all watchdog functions, the watchdog module is duplicated. The outputs are switched in parallel ('wired OR' function) to enable a trip of one section without losing the watchdog signal to the IO.

The below figures show the watchdog section and watchdog outputs schematics.

7 Control Processor modules

7.2 QPP-0002

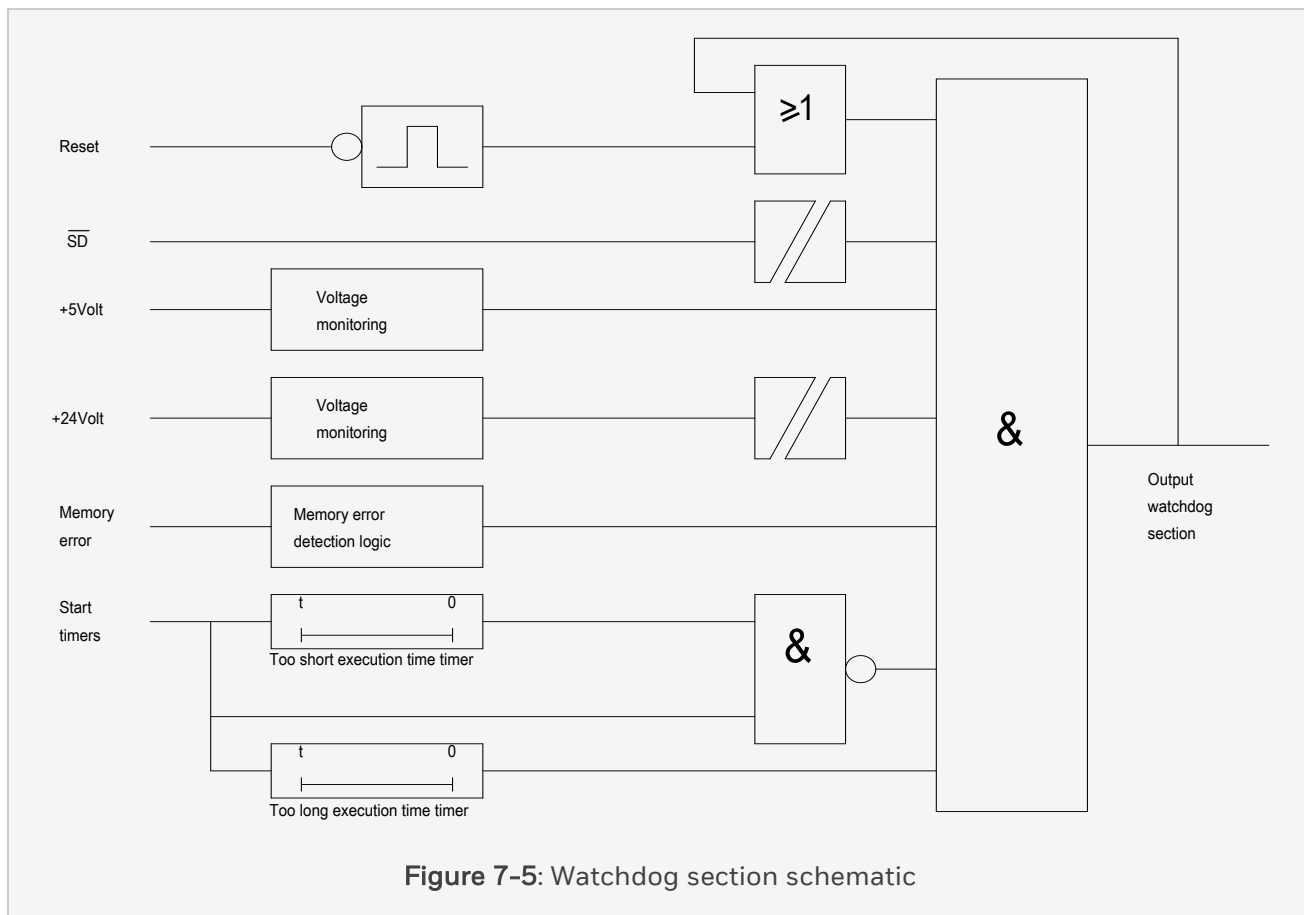
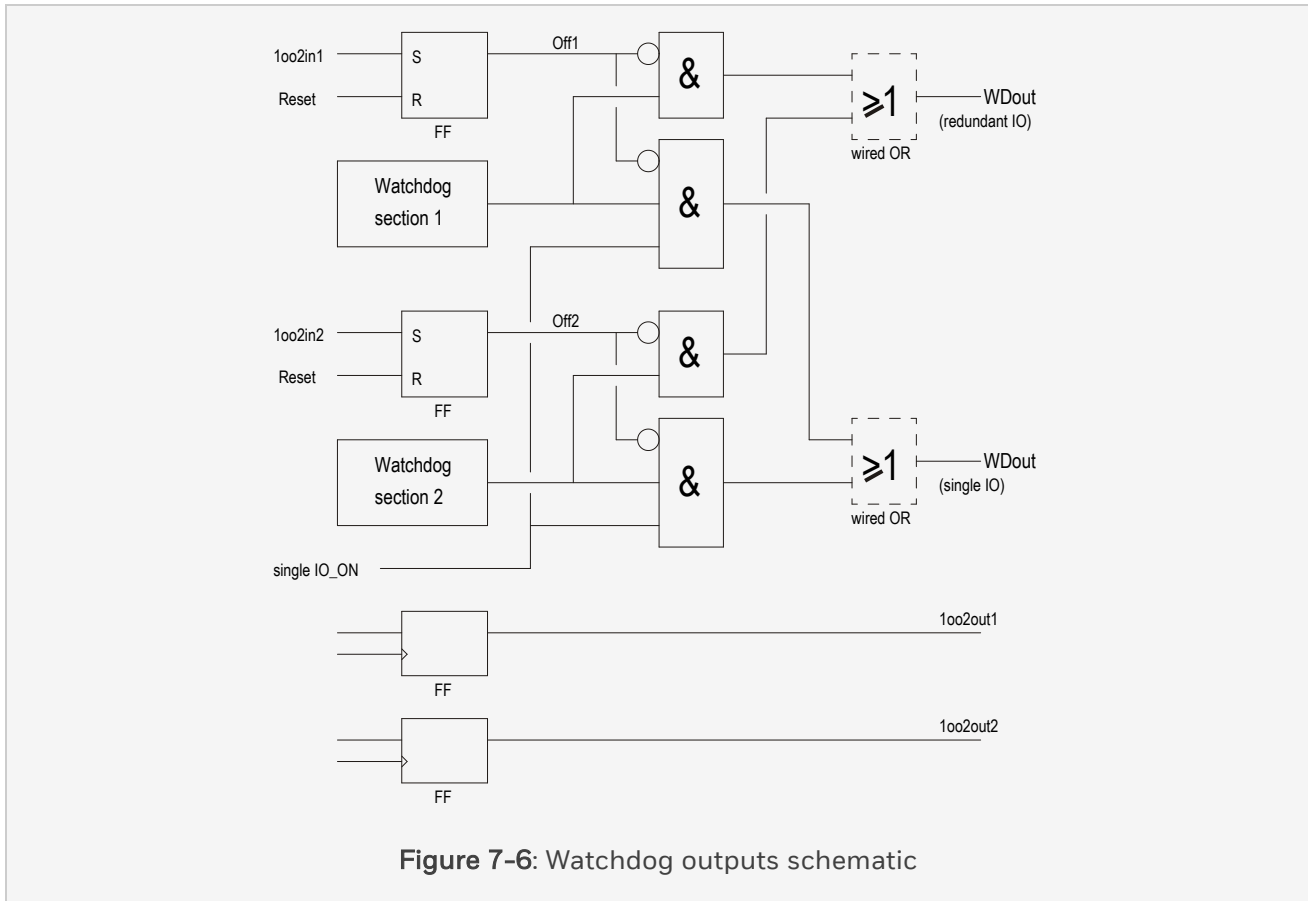

Figure 7-5: Watchdog section schematic



The lower two flip-flops in the above figure latch the (outgoing 1oo2D) commands to de-energize the watchdog (parts) of the (redundant) processor. These outputs of the (redundant) processor are connected to the (1oo2D) inputs of this watchdog ('1oo2in1' and '1oo2in2' in the above figure).

Each WD_{out} output can drive 750mA.

7.2.10 Diagnostics

The following diagnostics are performed by the QPP-0002 module:

- QPP-0002 generates an alarm and event when battery voltage drops below the data retention voltage. The “data retention voltage” is defined as the absolute minimum voltage needed for a device to correctly maintain the contents of their RAM circuits. This voltage is standard 2.0 V.
- QPP-0002 generates an alarm and event when the battery lifetime expires.
- The 5 V DC voltage ‘too high’ or ‘too low’ will be alarmed.

7 Control Processor modules

7.2 QPP-0002

The 24 V DC voltage 'too high' or 'too low' will be alarmed.

- The diagnostics on the hardware comparators will detect “stuck-at” and “shorts between inputs and outputs of the comparators”.
- The fault reaction to faults detected in the temperature monitoring function will result in an alarm, unless the temperature measured by the other Control Processor differs less than 3 degrees Celsius from a shutdown limit. In the latter case, an automatic shutdown of the Control Processor is initiated.
- Faults detected in the 10 ms base timer function result in automatic Control Processor shutdown.
- The fault reaction on a hardware failure detected by the hardware comparators of the application processor will result in an alarm to the safety processor, which initiates a Control Processor shutdown.

The following diagnostics are defined for the BKM-0001 (most electronics for execution of these functions are located on the QPP-0002):

- The BKM-0001 is not placed.
- Battery voltage is out of range (too high, too low and open circuit).
- The safety processor will have the capability and possibility to indicate a faulty battery status on the status LED of the BKM-0001.

7.2.11 Technical data

General	Type number:	FC-QPP-0002
	Operating temperature:	
	<ul style="list-style-type: none"> outside module temperature: 	-5°C-+70°C (+23°F-+158°F)
	<ul style="list-style-type: none"> inside module temperature: 	-5°C-+85°C (+23°F-+185°F)
	Storage temperature:	-40°C-+85°C (-40°F-+185°F)
	Relative humidity:	10-95% (non condensing)
	Approvals:	CE, UL, CSA, TUV, FM
Power	24 V supply voltage:	24 V DC -15%-+30%
	24 V supply current:	max. 25 mA
	5 V supply voltage:	5 V DC ± 5%
	5 V supply current:	max 1.2 A
+24 V _{sd}	Output supply voltage:	15-31 V DC
	Output resistance:	approx. 1.1 kΩ
	Short circuit proof:	continuous
SD input	Voltage (high):	15-32 V DC
	Voltage (low):	<4 V (reverse polarity protected)
	Input current:	approx. 8mA at 24 V DC
WD _{out} output	Output current:	750mA per output
Physical	Dimensions: (H × W× D)	176 × 88.5 × 212 mm
		6.93 × 3.48 × 8.35 in
	Weight:	1,3 kg