

# User Manual

## VIBRATION MONITOR

VibroSmart VMU100

MAVMU100/E





**CE 680 M411**

## Piezoelectric Accelerometer with Integrated Electronics Type CE 680 M411

### FEATURES

- Designed for medium temperature industrial applications (-55°C to +120°C)
- Shear mode operation, therefore no output due to thermal transients
- 2-pole low-pass filter for resonance suppression
- Hermetically sealed for harsh environments
- Ground isolated from case and connected to a Faraday shield
- Bias voltage stability at elevated temperatures
- Frequency response  $\pm 10\%$  3 to 5000 Hz  
 $\pm 3$  dB 0.5 to 10 000 Hz



### DESCRIPTION

The CE 680 M411 is an all-purpose vibration sensor designed for use in harsh industrial machinery environments. It uses the industry standard 2-wire voltage transmission technique with a 4 mA constant current supply. The output signal has a sensitivity of 100 mV/g.

Thanks to the accelerometer's isolated ground and Faraday shield, no ground loops or frame voltage are present to disturb the measurement.

The CE 680 M411 shows extremely low noise levels and exceptional bias voltage stability at elevated temperatures.

### PHYSICAL DIMENSIONS AND CONNECTING DIAGRAM

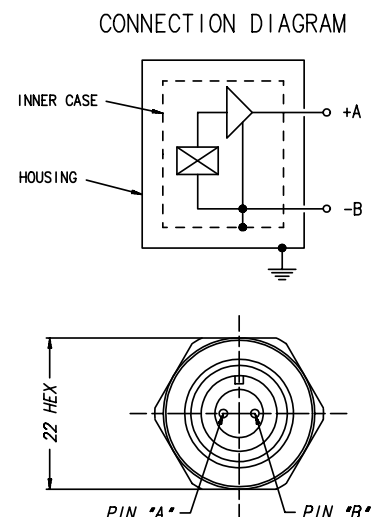
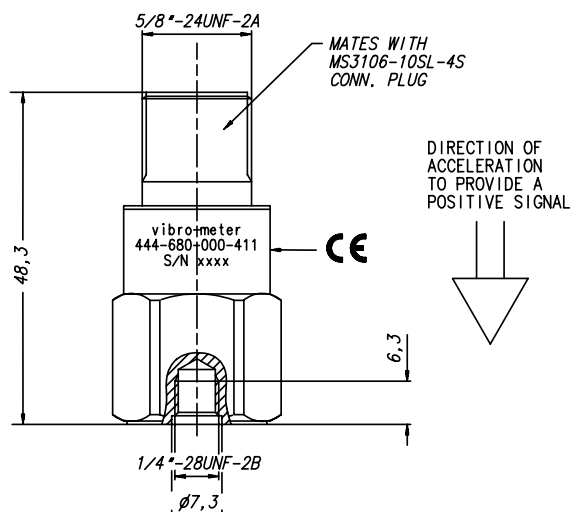

**SPECIFICATIONS**

**Note:** Unless otherwise stated, all values listed are typical values, referenced at +24°C, 24 VDC supply, 4 mA constant current and 100 Hz

**OPERATING**

(at +23°C ±5°C)  
 Sensitivity (at 120 Hz) : 100 mV/g ±10%  
 Dynamic range : 80 g  
 Transverse sensitivity : < 5%  
 Linearity : < 1% up to full-scale  
 Resonant frequency : Nominal 25 kHz, +15 dB max. at resonance

**ELECTRICAL**

Input supply current : 2 to 10 mA  
 Supply voltage for current source : 22 to 30 V<sub>DC</sub>  
 DC output bias voltage  
 • From -50 to +99°C : 11 to 14 VDC  
 • From +100 to +120°C : ≤ ±100 mV/°C  
 Output impedance : 50 Ω  
 Residual noise : 0.0005 g (from 2.5 Hz to 25 kHz) (+25°C or +120°C)  
 Isolation between inner case and housing : ≥ 10 MΩ  
 Over-voltage protection : > 40 V<sub>DC</sub>  
 Reversed polarity : Protected

**ENVIRONMENTAL**

Temperature range : -55°C to +120°C  
 Humidity : Hermetically sealed  
 Simusoidal vibration limit : 500 g peak  
 Shock limit : 5000 g peak  
 Base strain sensitivity : 0.002 µg peak/µε  
 ESD protection : > 36 V  
 EMC (10 V/m, 150 kHz to 1000 MHz with 80% AM at 1000 Hz) : 0.003 g peak to peak  
 MTBF : 197 000 hours (+25°C)  
 35 000 hours (+125°C)

**PHYSICAL**

Weight : 90 g  
 Case material : 316 L stainless steel  
 Mounting torque : 2.9 Nm  
 Mating connector : MS3106F-10SL-4S or equiv.

**CALIBRATION**

Dynamic calibration at factory. No subsequent calibration necessary.

**TYPICAL RESPONSE CURVES**

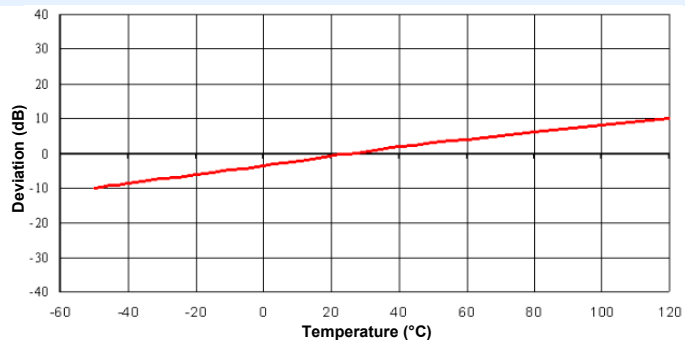
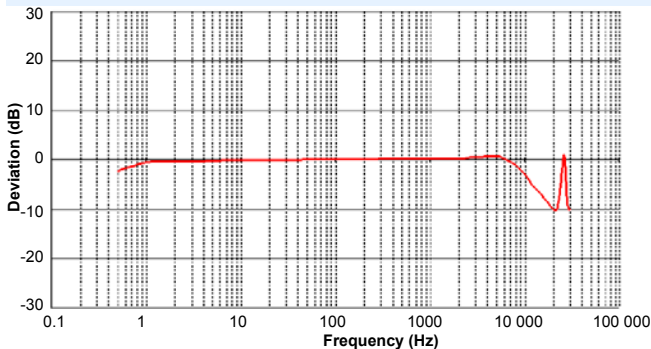

**ACCESSORIES**

**Supplied Accessories**

Adaptor stud	Type 1/4-28 UNF	P/N 2984-2
Adaptor stud	Type 1/4-28 to M8 x 1.25	P/N 2984-8

**Optional Accessories**

Cable	Type EC 318	P/N 922-318-000-0XX
Cable	Type EC 319 (with boot)	P/N 922-319-000-0XX

**ORDERING INFORMATION**

To order please specify :

Type	Designation	Ordering Number
CE 680 M411	Piezoelectric Accelerometer	444-680-000-411



In this publication, a dot (.) is used as the decimal separator and thousands are separated by spaces. Example : 12 345.678 90  
 Although care has been taken to assure the accuracy of the data presented in this publication, we do not assume liability for errors or omissions.  
 We reserve the right to alter any part of this publication without prior notice.

**Head Office**

**Vibro-Meter SA**  
 Rte de Moncor 4, P.O. Box,  
 CH-1701 Fribourg, Switzerland  
 Phone : +41 26 407 11 11  
 Fax : +41 26 407 13 01  
[www.vibro-meter.com](http://www.vibro-meter.com)

**Your Local Agent**

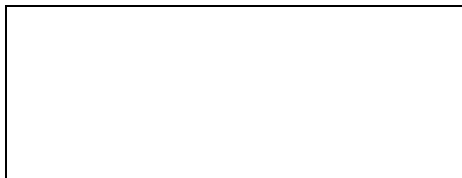

**Sales Offices**

Sales offices in :  
 • Germany • France  
 • USA • Canada  
 • Singapore • United Kingdom  
 • Russia • Ukraine  
 Agents in over 30 countries  
 Vibro-Meter is a member of the  
 Meggitt Aerospace Systems Division